

**2008
TOOLING REFERENCE GUIDE
VERSION 4.1**

TOOLING FOR MODELS



**250 GT
250 GT2**



**265
265-2
265-3**



310 / 311



MACHINE MODEL : ALL 250'S

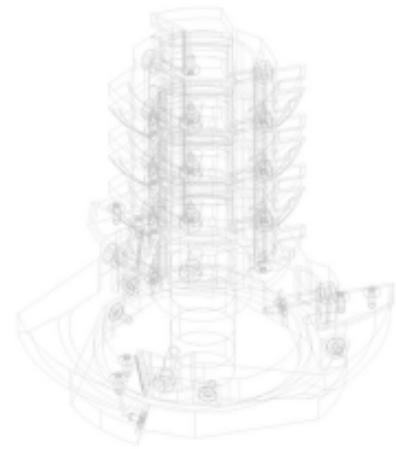
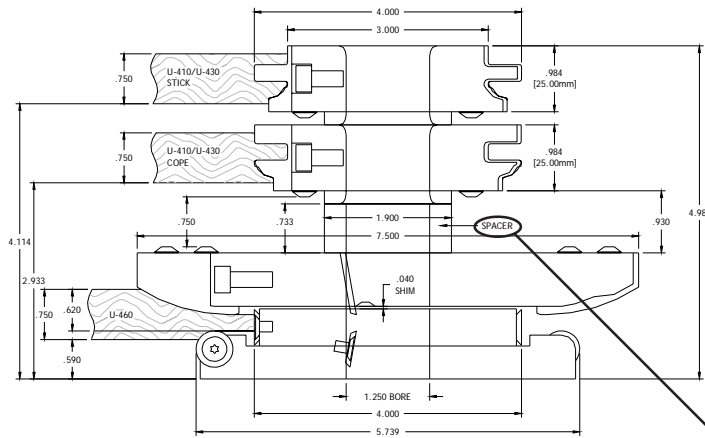

It is extremely important that this spacer be on the stack between small & large diameter tools.

** Spacer size varies between machine models.*

Please contact Unique to avoid bodily injury or machine damage.

- **When machining doors on the Unique Model 250:**
 1. Watch Training Video prior to operation.
 2. Feed materials at a brisk pace. Feeding too slow will prematurely wear tooling.
 3. When arching rails, feed thru 1/3 of the arch, pull straight back & climb cut the remainder of the arch. (NOTE: This may take some practice to become efficient)
 4. For beginners, an easy method to arch a rail is to insert the rail blank until it touches the stop. Back the blank out roughly 1/4-1/2". Cut the arch then push the cut part in again until it touches the stop and finish the cut. (NOTE: This method is not ideal for production but it is suitable for training purposes)

- **All Unique 250'S come standard with a complete set of tooling and one arching template. For shops with many profiles, an additional turret is recommended for ease of setup but is not required.**

Note: In order to utilize arching capabilities of the 250GT2, the Rail, Cope and Trim Cutter must maintain a constant OD of 4.00"

Always install inserts using proper torque rating for tool.

MACHINE MODEL : 265 & 310/311

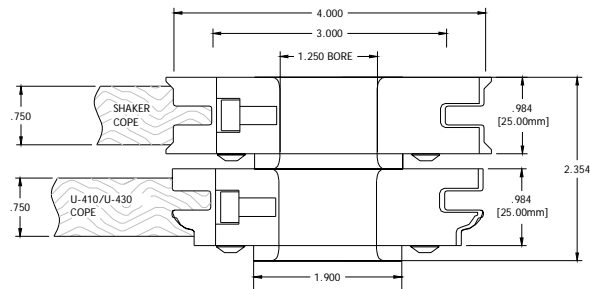
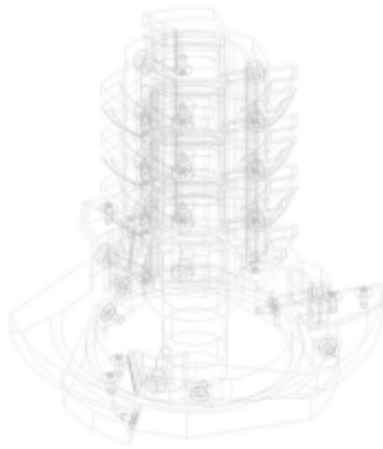

2008 Version 4.1

- **When machining cope/tenon profiles on the Unique Model 265 or 310/311:**
 1. Always use a backer board.
 2. Backer board should be “notched” to ensure sufficient part clamping.
 3. Feed the material quickly past the cutter head to help extend the life of the tooling.

- **All Unique coping machines are shipped without tooling. Customer tooling will be setup on new machine orders if tooling is recieved at Unique one week prior to machine delivery date. For multiple cutter models with many profiles, an additional turret is recommended for ease of setup but is not required.**

Always install inserts using proper torque rating for tool.

TECHNICAL NOTES

4" COPE & RAIL PROFILES

FOR MODELS 250,265,310,311

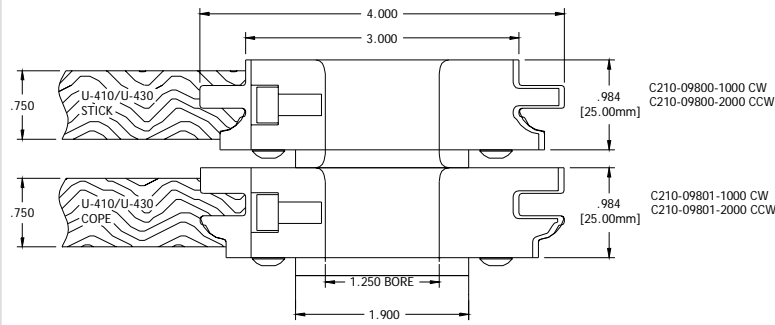

U410 / U430

The two profiles below run in the tools pictured to the left.

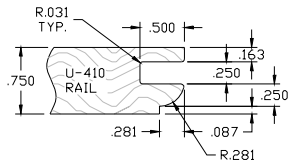

U410 RAIL INSERT
I810-09800-1000 CW
I810-09800-2000 CCW

U410 COPE INSERT
I810-09801-1000 CW
I810-09801-2000 CCW

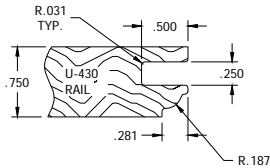
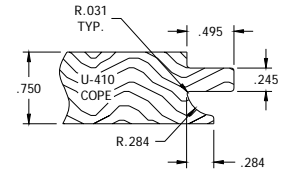

U430 RAIL INSERT
I810-09800-1100 CW
I810-09800-2100 CCW

U430 COPE INSERT
I810-09801-1100 CW
I810-09801-2100 CCW

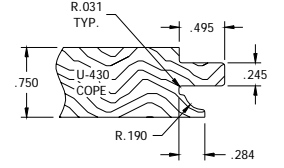

U336 / U600

The two profiles below run in the tools pictured to the right.

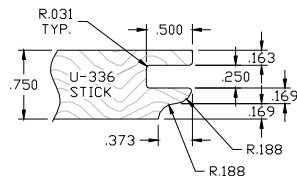
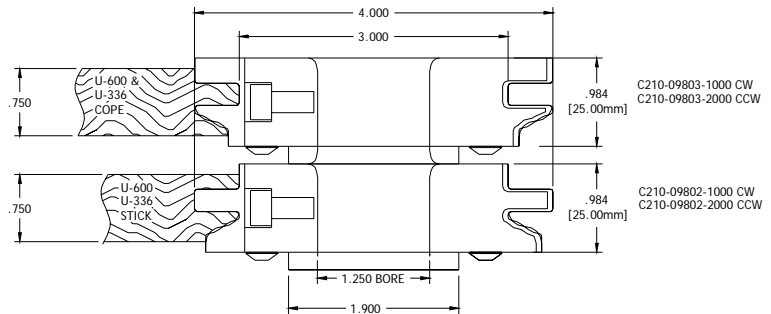

U336 RAIL INSERT
I810-09802-1000 CW
I810-09802-2000 CCW

U336 COPE INSERT
I810-09803-1000 CW
I810-09803-2000 CCW

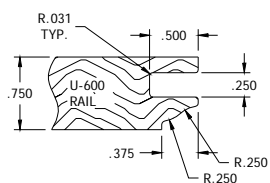
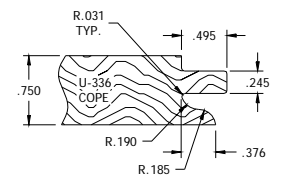

U600 RAIL INSERT
I810-09802-1100 CW
I810-09802-2100 CCW

U600 COPE INSERT
I810-09803-1100 CW
I810-09803-2100 CCW

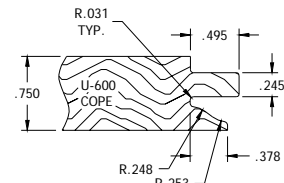

COPE & RAIL PROFILES

2008 Version 4.1

FOR MODELS 250,265,310,311

U410 /U430 GLASS

The two profiles below run in the tools pictured on the right.

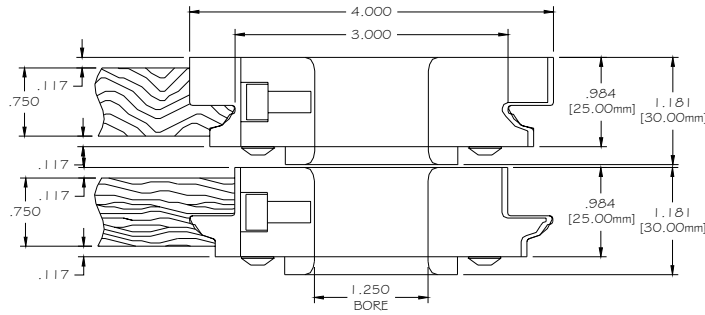

CUTTER NUMBER
C210-14302-1000 (CW)
C210-14302-2000 (CCW)

CUTTER NUMBER
C210-14303-1000 (CW)
C210-14303-2000 (CCW)

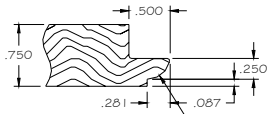

U410 GLASS RAIL INSERT
I810-14302-1000 CW
I810-14302-2000 CCW

U410 GLASS COPE INSERT
I810-14303-1000 CW
I810-14303-2000 CCW

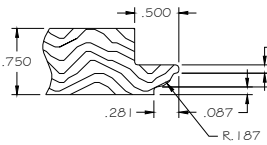
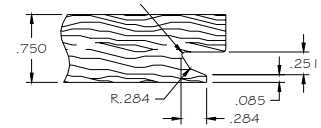

U430 GLASS RAIL INSERT
I810-14302-1100 CW
I810-14302-2100 CCW

U430 GLASS COPE INSERT
I810-14303-1100 CW
I810-14303-2100 CCW

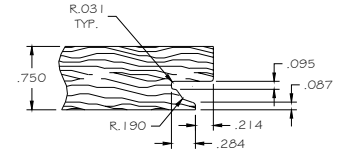

2008 Version 4.1

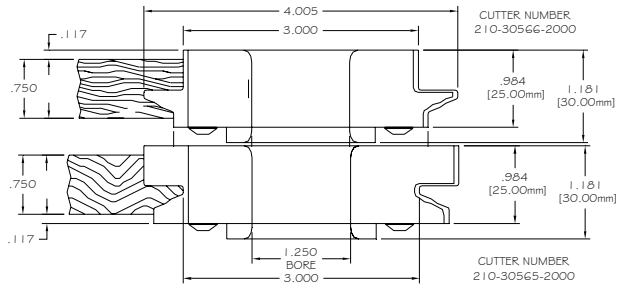

U600 GLASS

The profile below runs in the tools pictured on the left.
U336 also available upon request.

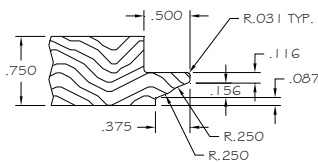

U600 GLASS RAIL INSERT
I810-30565-1000 CW
I810-30565-2000 CCW

U600 GLASS COPE INSERT
I810-30566-1000 CW
I810-30566-2000 CCW

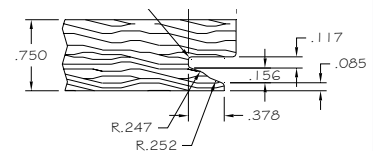

4" COPE & RAIL PROFILES

FOR MODELS 250,265,310,311

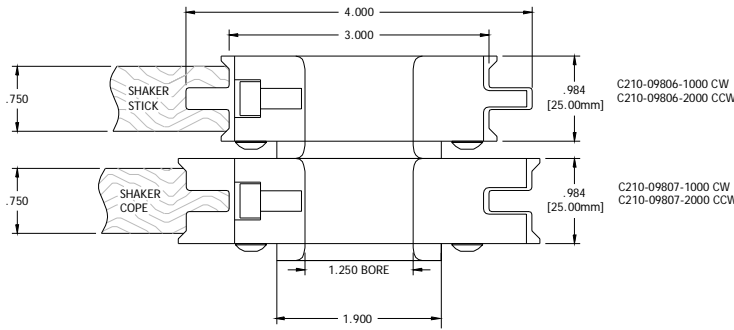

SHAKER

The three profiles below run in the tools pictured on the left.

C210-09806-1000 CW
C210-09806-2000 CCW

C210-09807-1000 CW
C210-09807-2000 CCW

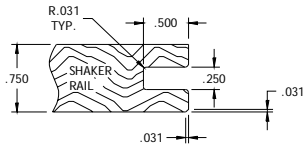

S1 RAIL INSERT
I810-09806-1000 CW
I810-09806-2000 CCW

S1 COPE INSERT
I810-09807-1000 CW
I810-09807-2000 CCW

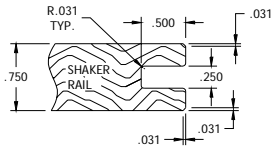
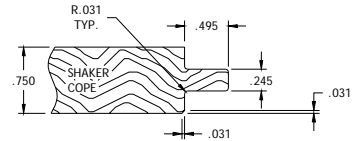

S2 RAIL INSERT
I810-09806-1100 CW
I810-09806-2100 CCW

S2 COPE INSERT
I810-09807-1100 CW
I810-09807-2100 CCW

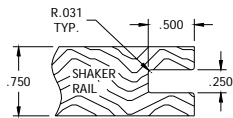
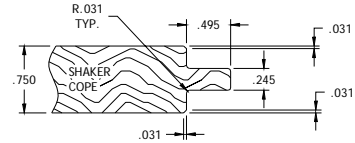

S3 RAIL INSERT
I810-09806-1200 CW
I810-09806-2200 CCW

S3 COPE INSERT
I810-09807-1200 CW
I810-09807-2200 CCW

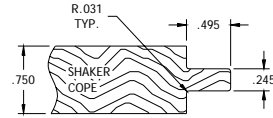

COPE & RAIL PROFILES

SHAKER GLASS

The two profiles below run in the tools pictured on the right.

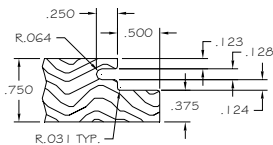
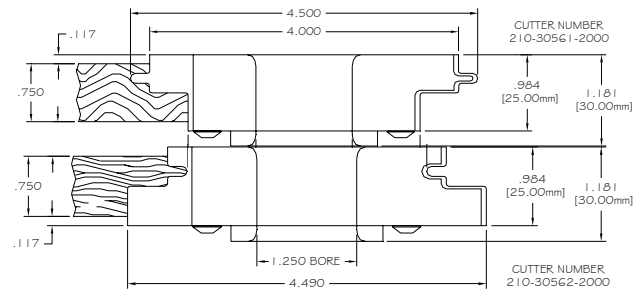

SHAKER GLASS RAIL INSERT
I810-30561-1000 CW
I810-30561-2000 CCW

SHAKER GLASS COPE INSERT
I810-30562-1000 CW
I810-30562-2000 CCW

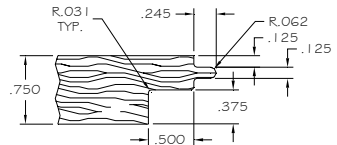

2008 Version 4.1

FOR MODELS 265,310,311 WITH 6" SETUP

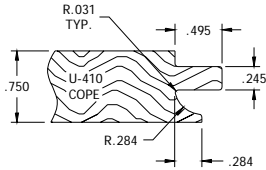
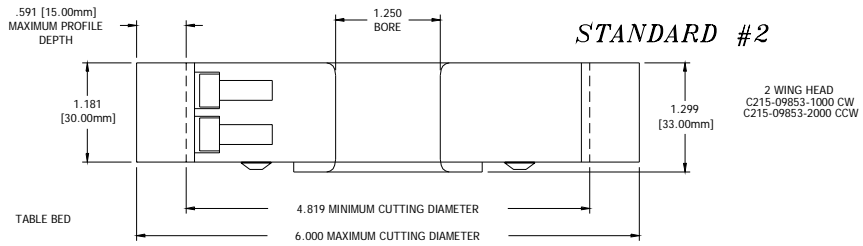
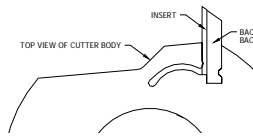

U410 COPE INSERT
I816-15264-1000 CW
I816-15264-2000 CCW
BACKER NUMBER
I850-15264-1000 CW
I850-15264-2000 CCW

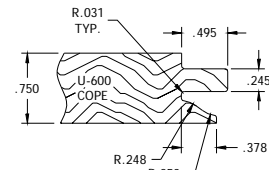

U600 COPE INSERT
I816-15119-1000 CW
I816-15119-2000 CCW
BACKER NUMBER
I850-15119-1000 CW
I850-15119-2000 CCW

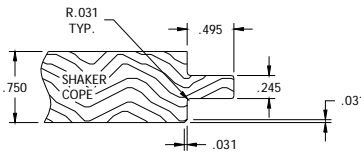

SHAKER 1 COPE INSERT
I816-15117-1000 CW
I816-15117-2000 CCW
BACKER NUMBER
I850-15117-1000 CW
I850-15117-2000 CCW

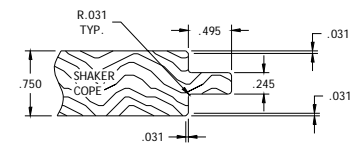

SHAKER 2 COPE INSERT
I816-15117-1000 CW
I816-15117-2000 CCW
BACKER NUMBER
I850-15117-1000 CW
I850-15117-2000 CCW

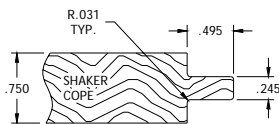

SHAKER 3 COPE INSERT
I816-15116-1000 CW
I816-15116-2000 CCW
BACKER NUMBER
I850-15116-1000 CW
I850-15116-2000 CCW

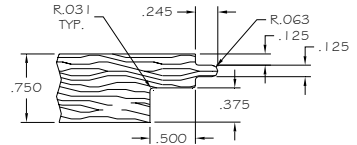

SHAKER 3 GLASS COPE INSERT
I816-32298-1000 CW
I816-32298-2000 CCW
BACKER NUMBER
I850-32298-1000 CW
I850-32298-2000 CCW

2008 Version 4.1

GREAT-LOC SG® COPE



FOR 5.2 MM PANEL THICKNESS

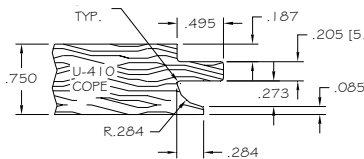

U410 COPE INSERT
I816-32299-1000 CW
I816-32299-2000 CCW
BACKER NUMBER
I850-32299-1000 CW
I850-32299-2000 CCW

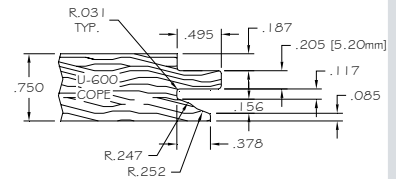

U600 COPE INSERT
I816-32300-1000 CW
I816-32300-2000 CCW
BACKER NUMBER
I850-32300-1000 CW
I850-32300-2000 CCW

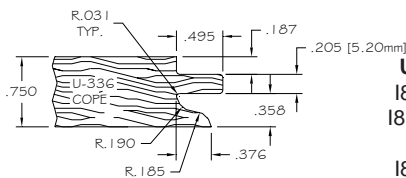

U336 COPE INSERT
I816-32301-1000 CW
I816-32301-2000 CCW
BACKER NUMBER
I850-32301-1000 CW
I850-32301-2000 CCW

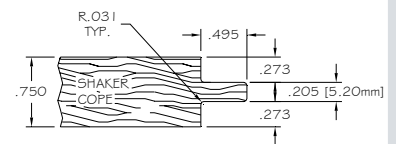

SHAKER 3 COPE INSERT
I816-32297-1000 CW
I816-32297-2000 CCW
BACKER NUMBER
I850-32297-1000 CW
I850-32297-2000 CCW

FOR MODEL 250

RAISED PANEL PROFILES

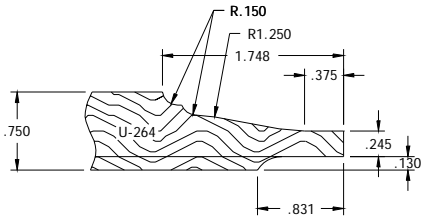
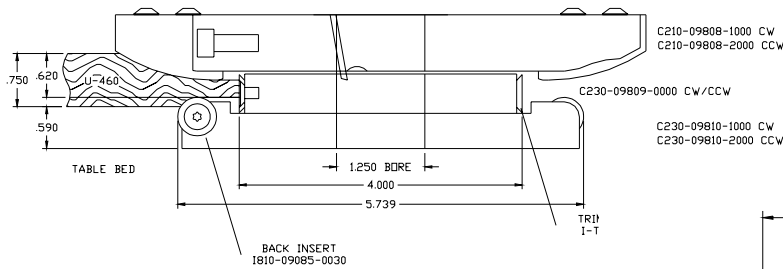

U264 INSERT NUMBER
1810-09808-2400 CCW

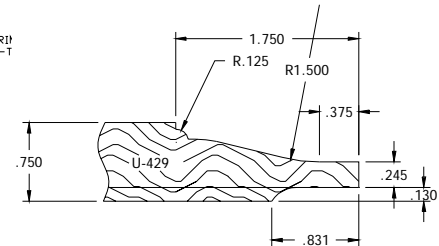

U429 INSERT NUMBER
1810-09808-2100 CCW

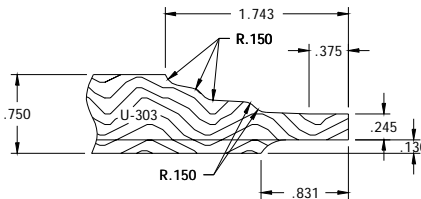

U303 INSERT NUMBER
1810-09808-2700 CCW

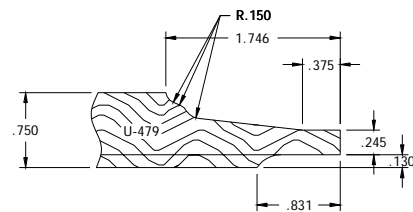

U479 INSERT NUMBER
1810-09808-2300 CCW

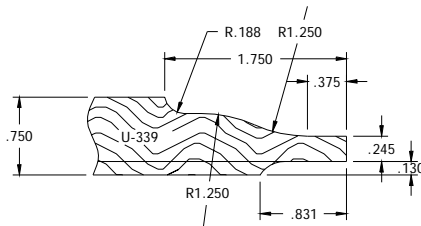

U339 INSERT NUMBER
1810-09808-2200 CCW

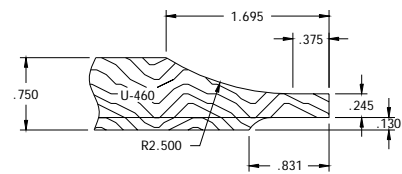

U460 INSERT NUMBER
1810-09808-2500 CCW

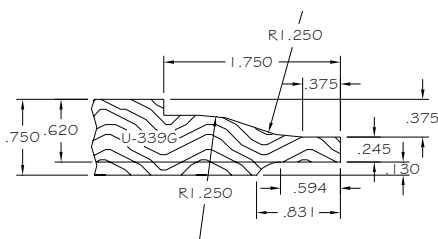

U339G INSERT NUMBER
1810-09808-2900 CCW

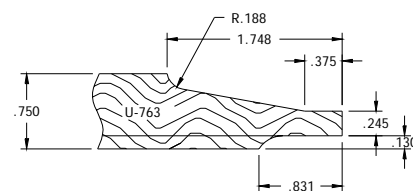

U763 INSERT NUMBER
1810-09808-2000 CCW

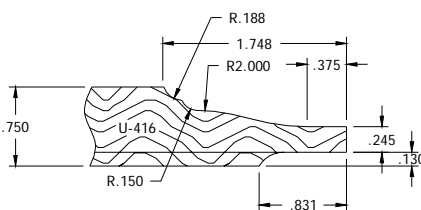

U416 INSERT NUMBER
1810-09808-2600 CCW

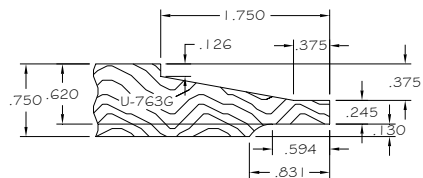

U763G INSERT NUMBER
1810-09808-2120 CCW

2008 Version 4.1

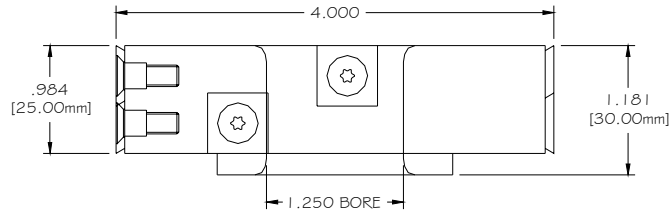

4" OD HOGGER FOR ALL 250 MODELS
C230-15030-2000

USED FOR PRE-ARCHING PANELS TO
MACHINE ON UNIQUE SHAPE AND SAND

REPLACEMENT INSERT NUMBER
I-TRIM-GR8

2008 Version 4.1

HOGGER TOOLS

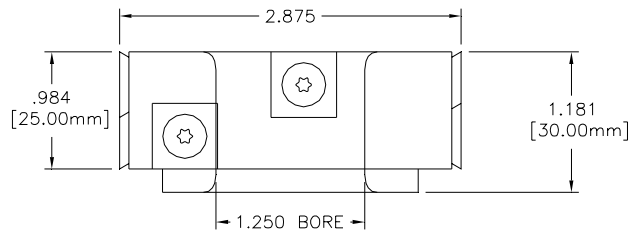

2.875" OD HOGGER FOR 250GT2XS
C230-28875-2000

USED FOR HOGGING RAIL ON 250GT2

REPLACEMENT INSERT NUMBER
I-TRIM-GR8

FOR MODELS 250,265,310,311

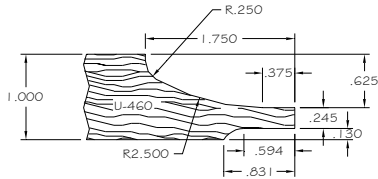
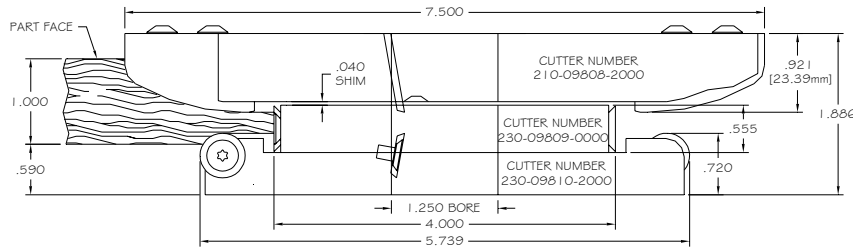

U460

PLEASE CALL THE UNIQUE TOOLING DEPARTMENT FOR PART NUMBERS AND DETAILS

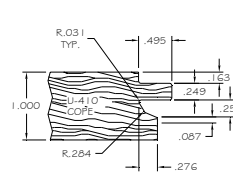
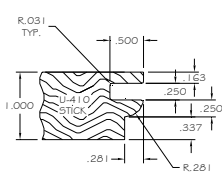
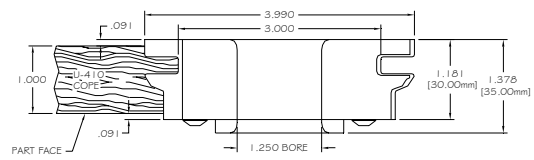
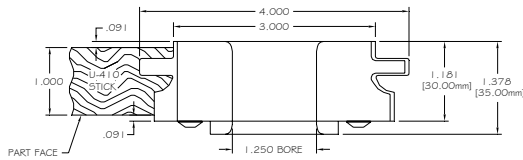

U410

PLEASE CALL THE UNIQUE TOOLING DEPARTMENT FOR PART NUMBERS AND DETAILS

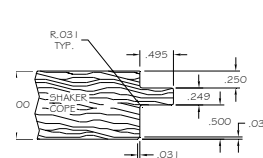
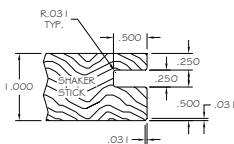
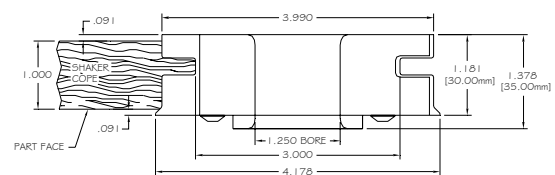
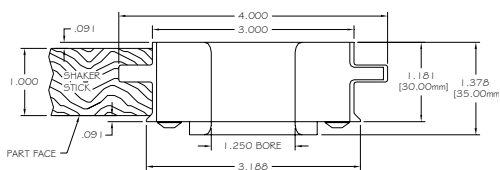

SHAKER

PLEASE CALL THE UNIQUE TOOLING DEPARTMENT FOR PART NUMBERS AND DETAILS

SPECIAL 1" THICK CABINET DOOR TOOLS

2008 Version 4.1

FOR MODELS 250,265,310,311

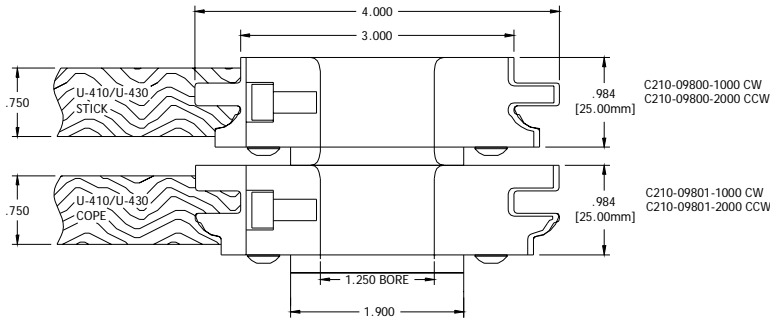

NEW
FOR 5.2MM PANELS

U410 / U430

The two profiles below run in the tools pictured to the left.

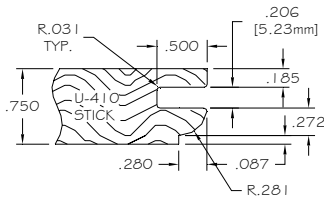

U410 RAIL INSERT
I810-09800-1200 CW
I810-09800-2200 CCW

U410 COPE INSERT
I810-09801-1200 CW
I810-09801-2200 CCW

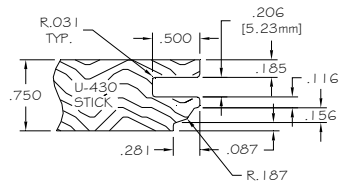
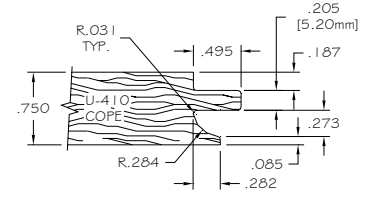

U430 RAIL INSERT
I810-09800-1300 CW
I810-09800-2300 CCW

U430 COPE INSERT
I810-09801-1300 CW
I810-09801-2300 CCW

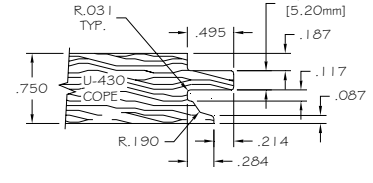

2008 Version 4.1

U336 / U600

These two profiles are also available in 5.2mm

All 5.2mm cope/rail profiles require special back cutter for 250GT tool stack
PN# C230-09810-2100

SPECIAL 4" COPE & RAIL PROFILES FOR 5.2 MM PANELS

FOR MODELS 250,265,310,311

SPECIAL 4" COPE & RAIL PROFILES FOR 5.5 MM PANELS

NEW
FOR 5.5 MM PANELS
SHAKER

The shaker profile below runs in the tools pictured to the left. S1 & S2 versions also available

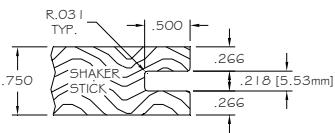
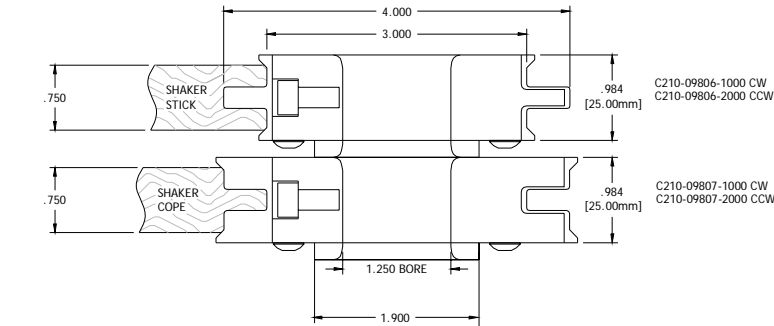

S3 RAIL INSERT
I810-32090-1000 CW
I810-32090-2000 CCW

S3 COPE INSERT
I810-32091-1000 CW
I810-32091-2000 CCW

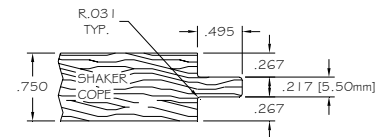

U600

The ogee profile below runs in the tools pictured to the right. U336 version also available

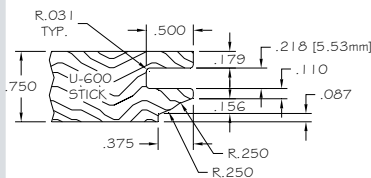
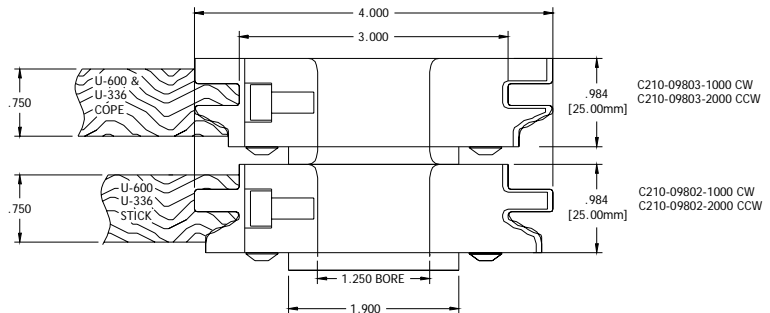

U600 RAIL INSERT
I810-32088-1000 CW
I810-32088-2000 CCW

U600 COPE INSERT
I810-32089-1000 CW
I810-32089-2000 CCW

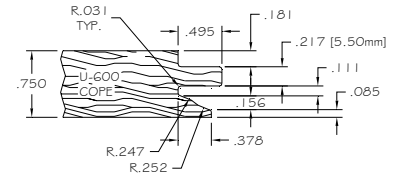

2008 Version 4.1

**TOOLING
FOR
MODELS**



FOR MODEL 318

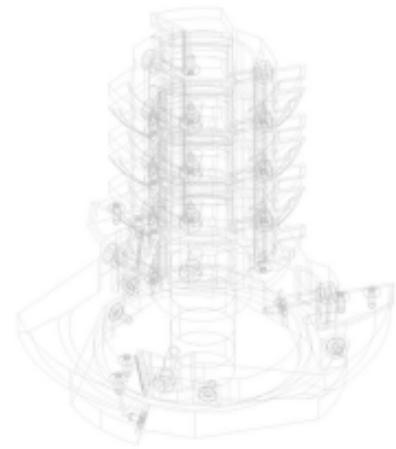
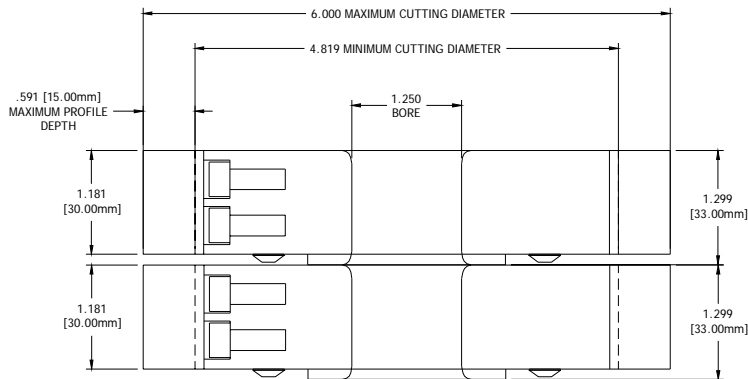

- **When machining stile profiles on the Unique Model 318:**
 1. Always use 6.00" constant OD tooling. Tooling exceeding 6.00" OD will damage the machine and tooling. Tooling under 6.00" OD will not machine parts consistently,
 2. Set the fence to the desired finished part size.
(NOTE: It is not recommended to remove less than 1/32" of material or no more than 3/16" material a pass)
 3. Always verify that there is sufficient hold down pressure, the machine climb cuts in the same direction as the feed direction.

- All Unique coping machines are shipped without tooling. Customer tooling will be setup on new machine orders if tooling is recieved at Unique one week prior to machine delivery date.

Always install inserts using proper torque rating for tool.

CLIMB CUT VERSION
DEDICATED - NO BACKER REQUIRED
FOR MODELS 318

U410 / U430

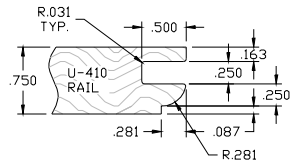
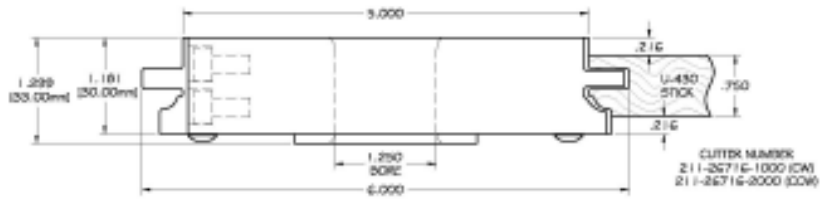

U410 INSERT NUMBER
I811-26716-2000 CCW CLIMB

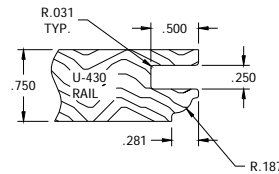

U430 INSERT NUMBER
I811-26716-2100 CCW CLIMB

2008 Version 4.1

GREAT-LOC STILE PROFILES

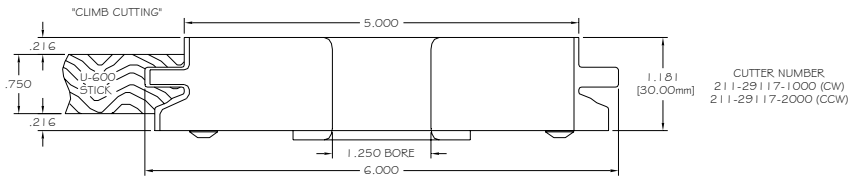

U336 / U600

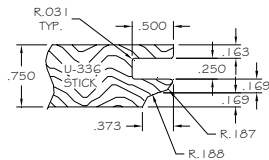

U336 INSERT NUMBER
I811-29117-2000 CCW CLIMB

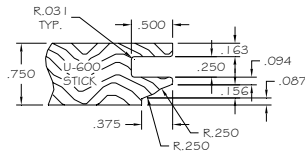

U600 INSERT NUMBER
I811-29117-2100 CCW CLIMB

SHAKER

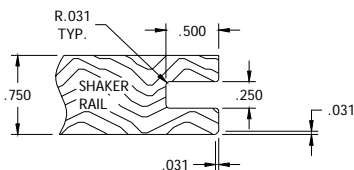
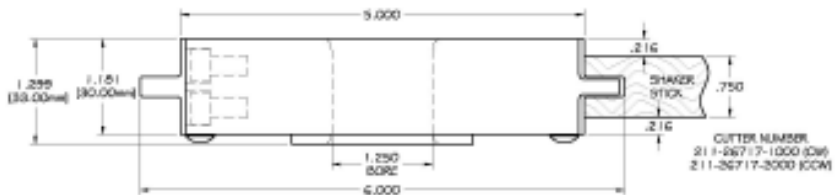

SHAKER 1 INSERT NUMBER
I811-26717-2100 CCW CLIMB

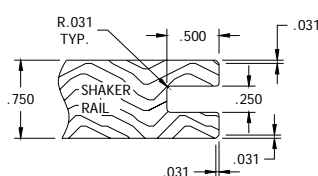

SHAKER 2 INSERT NUMBER
I811-26717-2000 CCW CLIMB

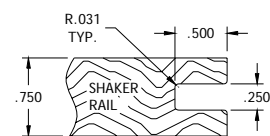

SHAKER 3 INSERT NUMBER
I811-26717-2200 CCW CLIMB

CLIMB CUT VERSION

DEDICATED - NO BACKER REQUIRED
FOR 5.2 MM PANEL ON MODELS 318

NEW
FOR 5.2 MM PANELS

GREAT-LOC STILE PROFILES FOR 5.2 MM PANELS

U410 / U430

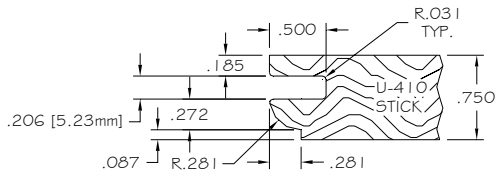
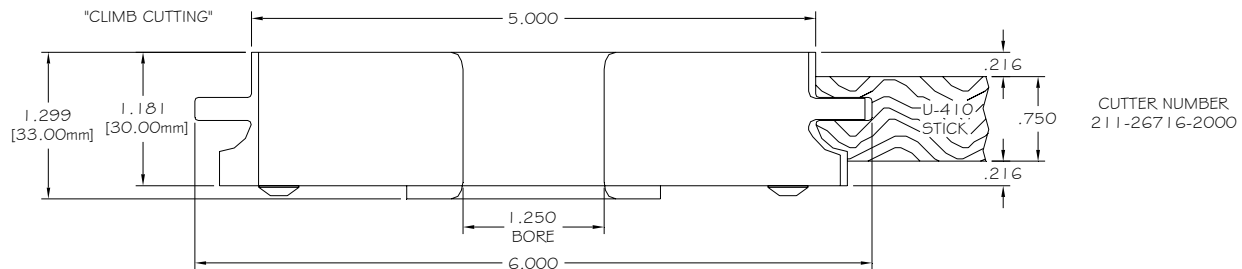

U410 INSERT NUMBER
I811-32304-2000 CCW CLIMB

U336 / U600

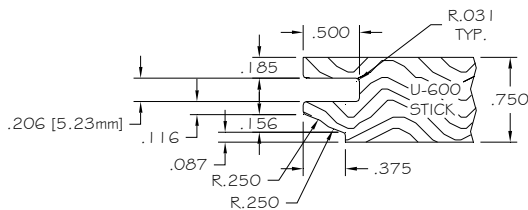
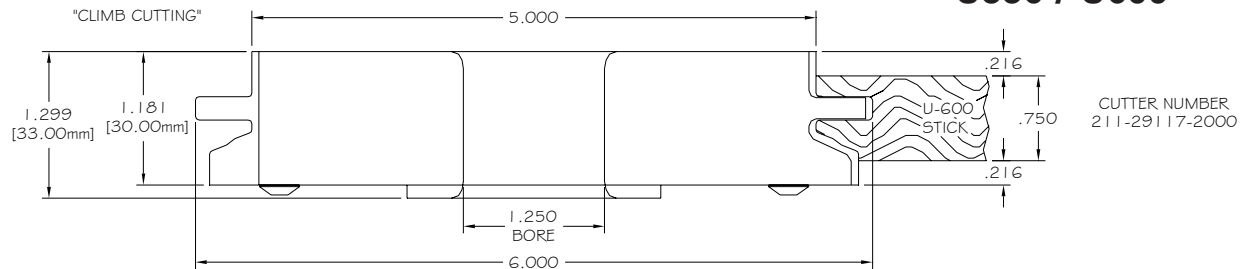

U600 INSERT NUMBER
I811-32305-2000 CCW CLIMB

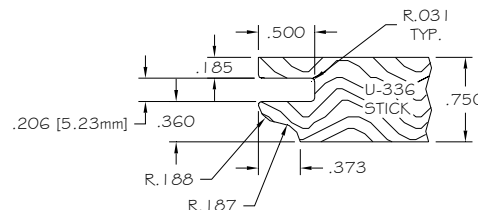

U336 INSERT NUMBER
I811-32306-2000 CCW CLIMB

2008 Version 4.1

NEW
FOR 5.2 MM PANELS

CLIMB CUT VERSION

**DEDICATED - NO BACKER REQUIRED
FOR 5.2 MM PANEL ON MODELS 318**

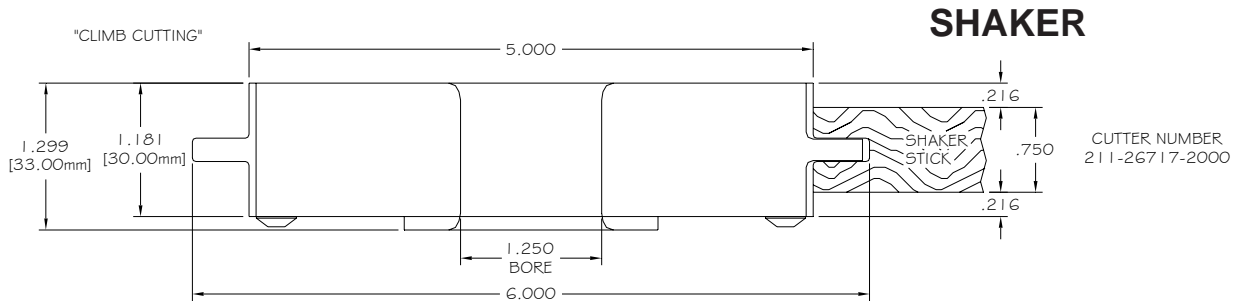

S3 INSERT NUMBER
1811-32302-2000 CCW CLIMB

2008 Version 4.1

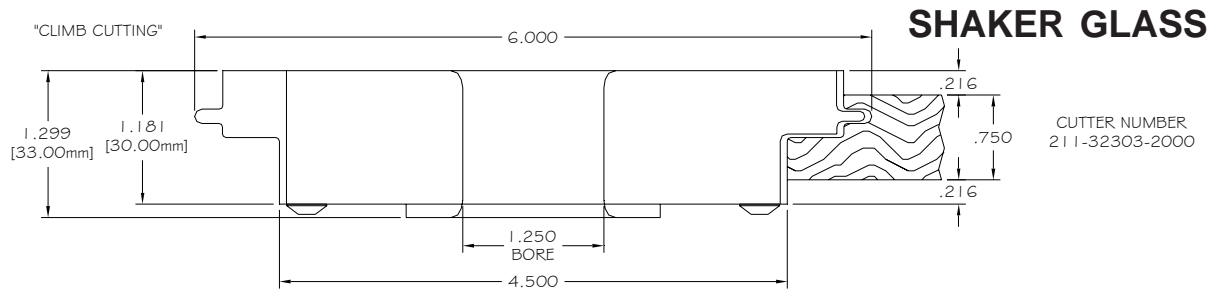

S3 GLASS INSERT NUMBER
1811-32303-2000 CCW CLIMB

GREAT-LOC STILE PROFILES FOR 5.2 MM PANELS

**TOOLING
FOR
MODELS**



319S
319SS



MACHINE MODEL : 319S / 319SS

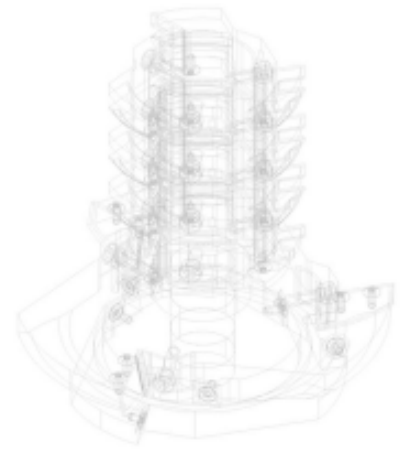
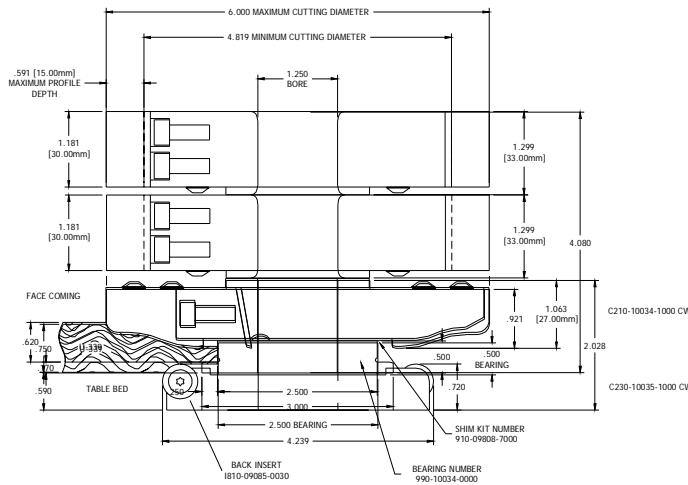

- **When machining doors on the Unique Model 319S / 319SS:**
 1. Always use 6.00" constant OD tooling. Tooling exceeding 6.00" OD will damage the machine and tooling. Tooling under 6.00" OD will not machine parts consistently,
 2. Material must be straight and sized prior to machining on the Model 319S/319SS
(NOTE: It is not recommended to remove less than 1/32" of material or no more than 3/16" material a pass)
 3. **SANDING SETUP:** Cut the material first with the sand station all the way back so it will not contact the material. E-Stop the machine when the profiled material is completely in front of the sand station. Position the sand tool towards the material until it makes contact. Make final adjustments and record that position for that profile for future reference.
- All Unique 319S/319SS machines are shipped without tooling. Customer tooling will be setup on new machine orders if tooling is received at Unique one week prior to machine delivery date.

Please reference Panel and edge detail profiles in the Shape & Sand section for tooling which can be run on the 319S / 319SS

Always install inserts using proper torque rating for tool.

**TOOLING
FOR
MODELS**

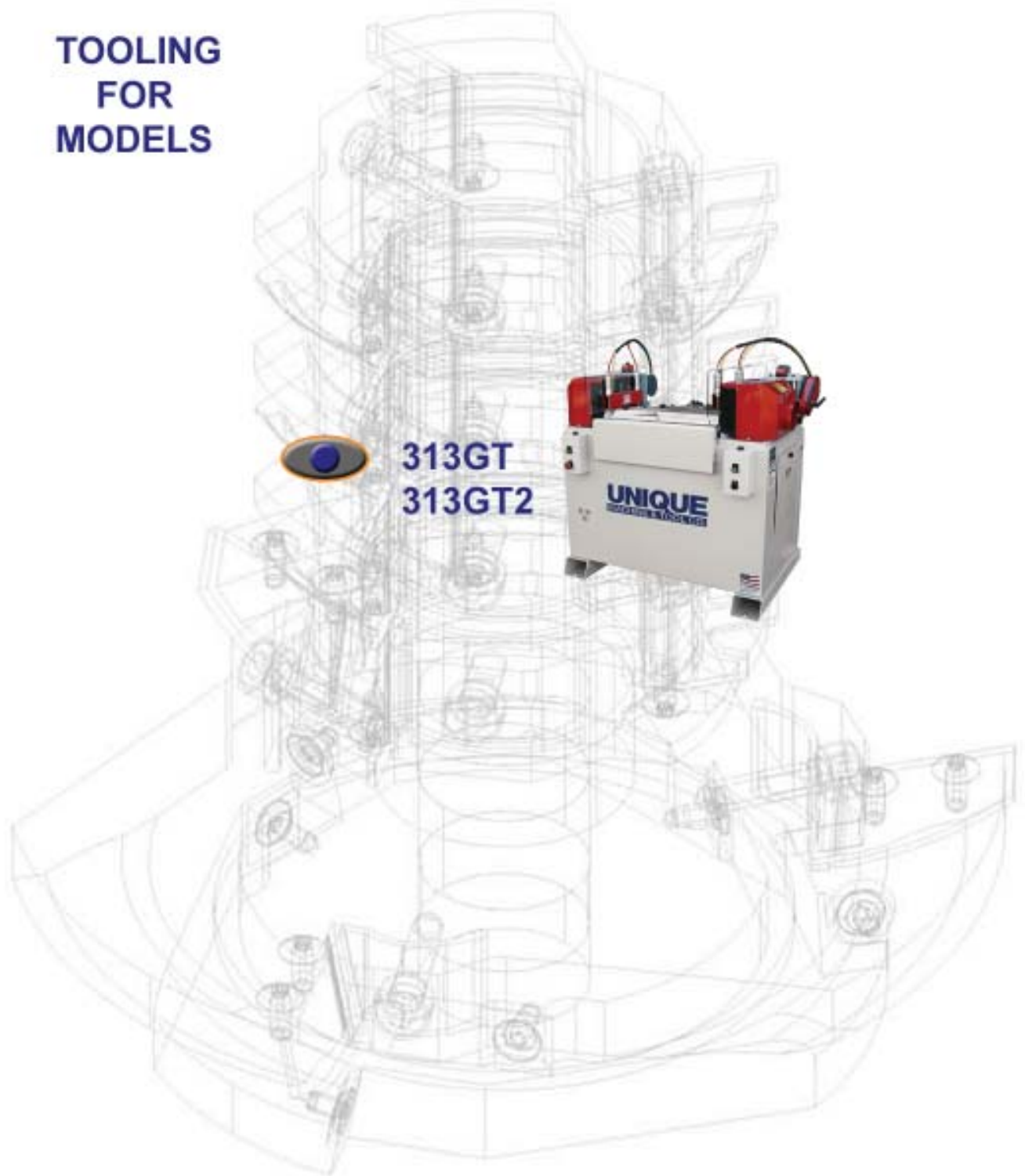

**313GT
313GT2**



MACHINE MODEL : 313

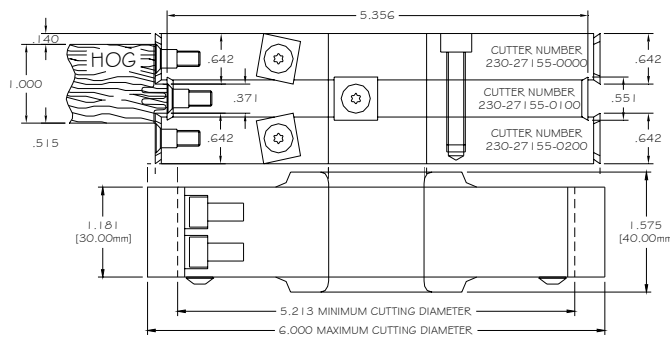
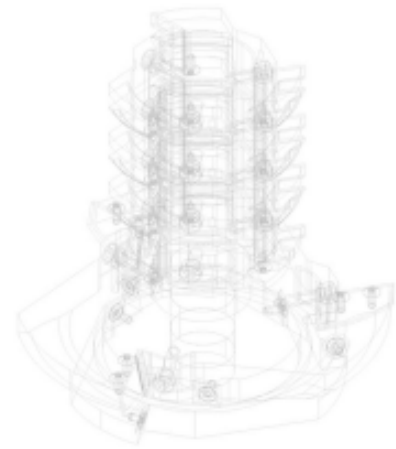
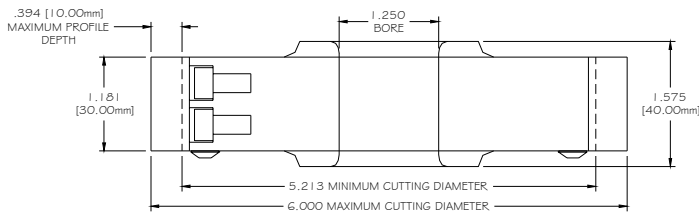

FOR 313GT2 MODELS

- **When machining doors on the Unique Model 313:**
 1. Material must be exact prior to machining on the Model 313.
 2. Material Check process
 - Check thickness
 - Check width
 - Check finished length
 - Check profile

** Use calipers to check the dimensions*
 3. The 313 machine table must be completely clean and void of any debris prior to loading material.
 4. The Model 313 is a very precise machine tool and is capable of producing very accurate miter joints. To ensure perfect joints use consistently sized material. Poor material quality will not yield a good joint.
- All Unique 313'S come standard with a complete set of tooling. Model 313GT2 comes with counter rotating hogging tools.

Always install inserts using proper torque rating for tool.

MACHINE MODEL : 313

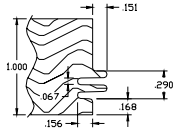

FJ1 INSERT NUMBER
I816-09851-1000 CW
I816-09851-2000 CCW
BACKER NUMBER
I850-09851-1000 CW
I850-09851-2000 CCW

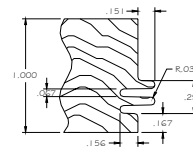
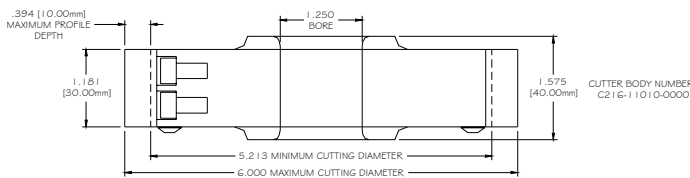
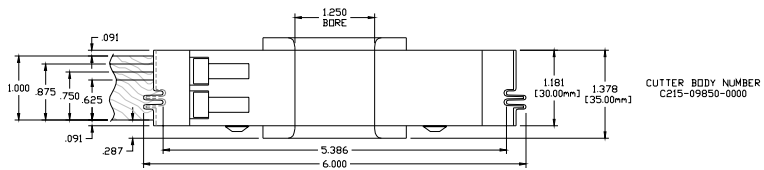

FJ2 INSERT NUMBER
I816-11011-1200 CW
I816-11011-2000 CCW
BACKER NUMBER
I850-11011-1100 CW
I850-11011-2000 CCW

DIAMOND FINGER JOINT TOOL

CUTTER NUMBER
C290-23703-1000 CW
C290-23704-2000 CCW

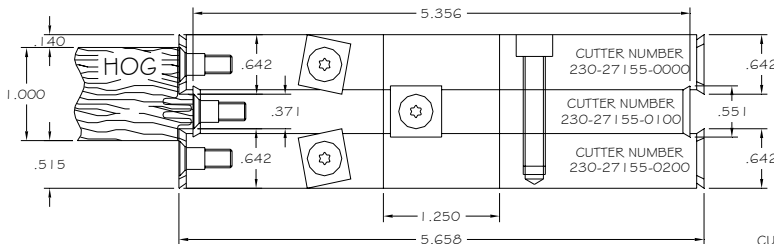
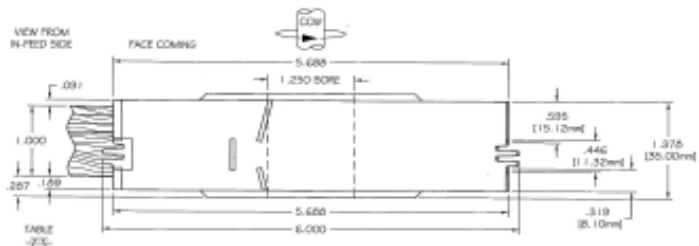

FOR 313GT2 MODELS ONLY

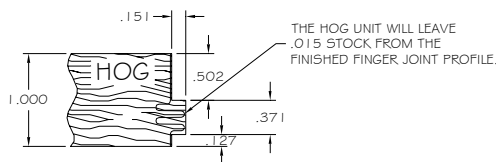

REPLACEMENT INSERTS
I332394
QTY 9 PER TOOL

**TOOLING
FOR
MODELS**



FOR MODELS 3450

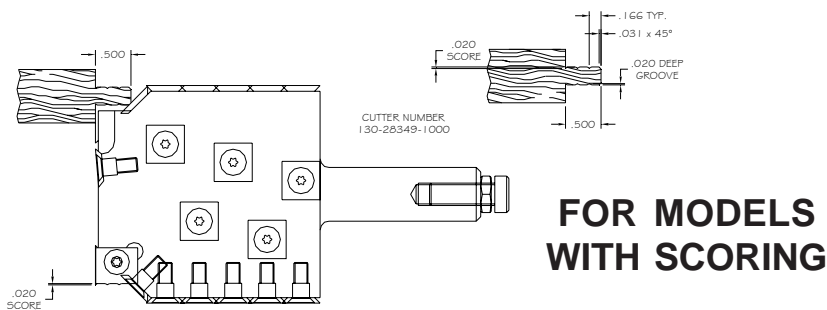
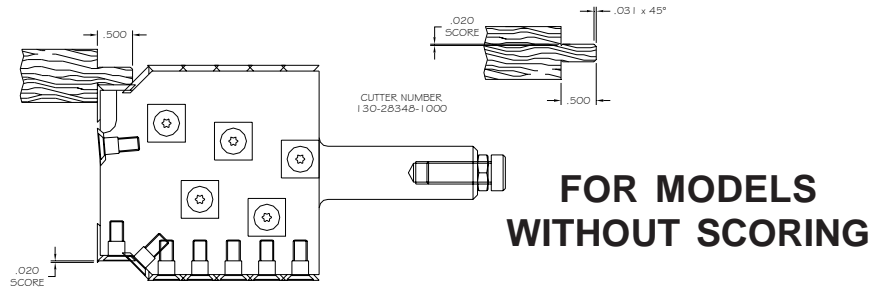

ADDITIONAL TOOLING



HOGGING INSERTS
PART NUMBER
I-TRIM-GR8
QTY 16 PER TOOL

MORTISE BIT



MORTISE EXT



SCORING INSERTS
PART NUMBER
1810-26876-1000
QTY 2 PER TOOL

PART NUMBER
C3450-MORTBIT

PART NUMBER
04895



MORTISE SPINDLE
PART NUMBER
04232-1/2



MORTISE EXT.
PART NUMBER
04216-3/8

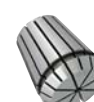

TENON SPINDLE
PART NUMBER
04232-3/4

**TOOLING
FOR
MODELS**



3503



FOR MODELS 3503

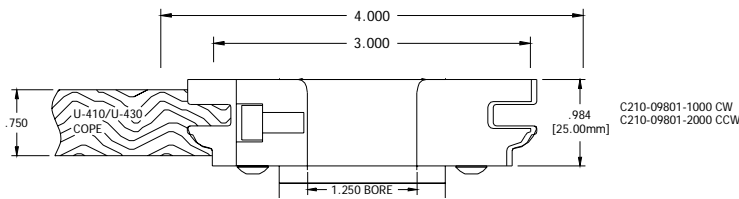

U410 / U430 COUNTER ROTATING CUTTERS REQUIRED

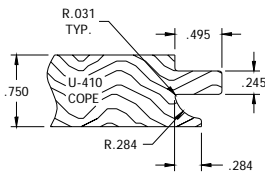

U410 COPE INSERT
I810-09801-1000 CW
I810-09801-2000 CCW

U430 COPE INSERT
I810-09801-1100 CW
I810-09801-2100 CCW

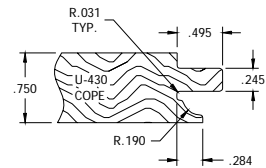

COPE PROFILES

U336 / U600 COUNTER ROTATING CUTTERS REQUIRED

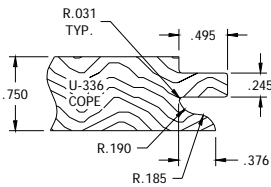
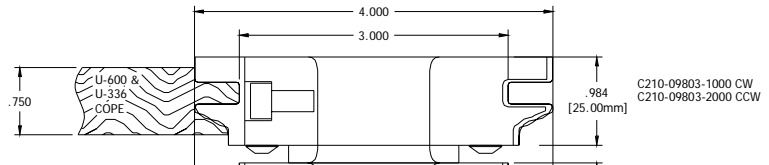

U336 COPE INSERT
I810-09803-1000 CW
I810-09803-2000 CCW

U600 COPE INSERT
I810-09803-1100 CW
I810-09803-2100 CCW

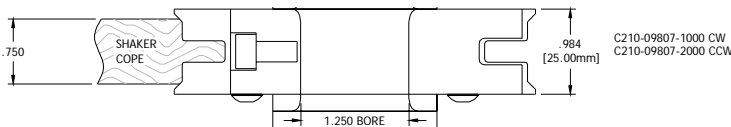
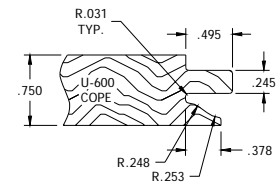

SHAKER COUNTER ROTATING CUTTERS REQUIRED

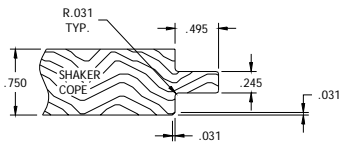

S1 COPE INSERT
I810-09807-1000 CW
I810-09807-2000 CCW

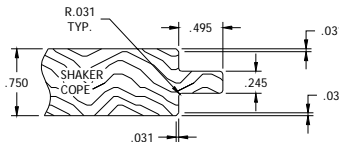

S2 COPE INSERT
I810-09807-1100 CW
I810-09807-2100 CCW

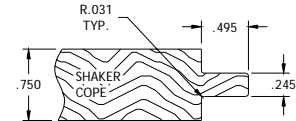

S3 COPE INSERT
I810-09807-1200 CW
I810-09807-2200 CCW

2008 Version 4.1

U410 / U430
ALSO AVAILABLE IN U336 / U600

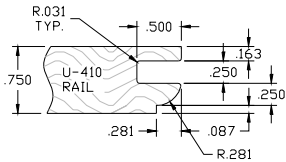
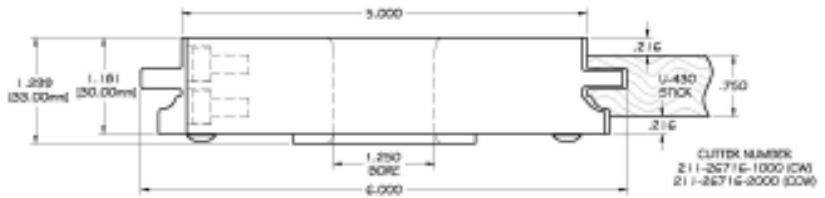

U410 INSERT NUMBER
I811-26716-1000 CW

U430 INSERT NUMBER
I811-26716-1100 CW

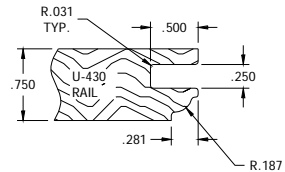

CUTTER NUMBER
Z11-26716-1000 (CW)
Z11-26716-2000 (CCW)

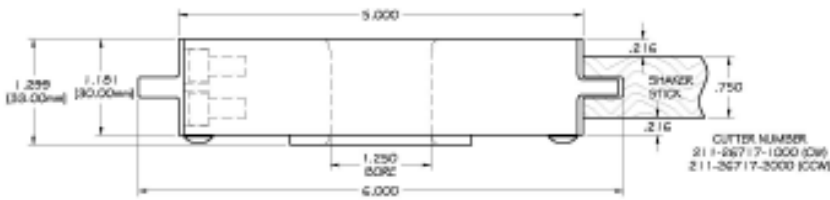

SHAKER

2008 Version 4.1

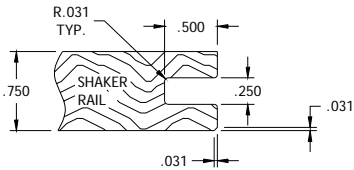

SHAKER 1 INSERT NUMBER
I811-26717-1100 CW

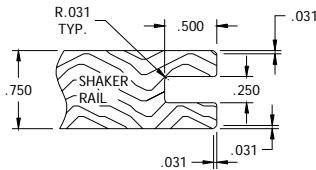

SHAKER 2 INSERT NUMBER
I811-26717-1000 CW

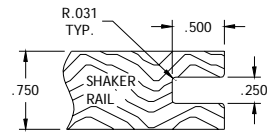

SHAKER 3 INSERT NUMBER
I811-26717-1200 CW

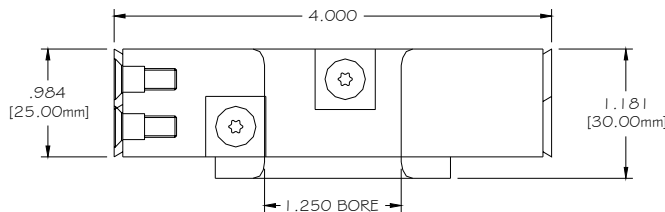

CUTTER NUMBER
C230-15030-1000 (CW)
C230-15030-2000 (CCW)

**COUNTER ROTATING
CUTTERS REQUIRED**

RAIL & HOGGER PROFILES

TOOLING FOR MODELS

 336-4



 4500



 2753



MACHINE MODEL : SHAPE & SAND

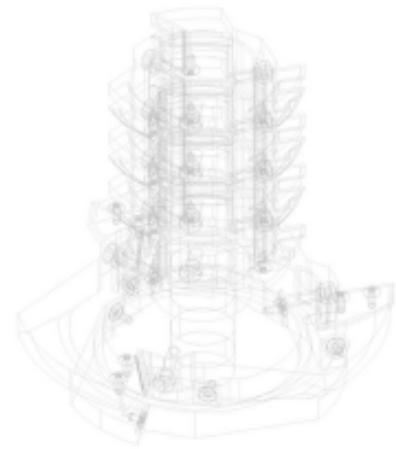
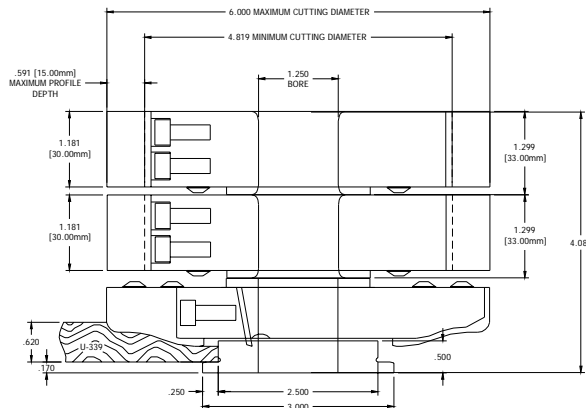

- **When machining panels on Unique Shape & Sands:**

1. A support bearing is recommended when no back cutter is used.

2. When machining raised panels on machines with two shapers, a roughing cutter on the first spindle can be used to remove the majority of the material thus saving tooling life on the second spindles profile inserts.

3. If using a sizing "InSet" fence it is recommended that a trim cutter is used under the panel cutter to dimension the part. This configuration may change some depending on the number of shaper heads used on the machine.

- **All Unique Shape & Sands come standard with floating heads for arched raised panel shaping and sanding. All Unique Shape & Sand machines are shipped without tooling. Customer tooling will be setup on new machine orders if tooling is received at Unique one week prior to machine delivery date.**

Always install inserts using proper torque rating for tool.

MACHINE MODEL : SHAPE & SAND

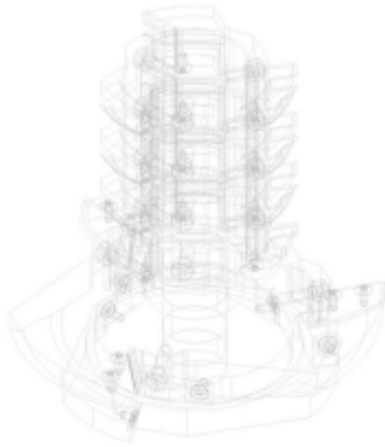

**TYPICAL SHAPE AND SAND SETUP
FOR PANELS**

CCW Panel Sander

CW Panel Sander

CCW Panel Finisher

CCW Panel Rougher

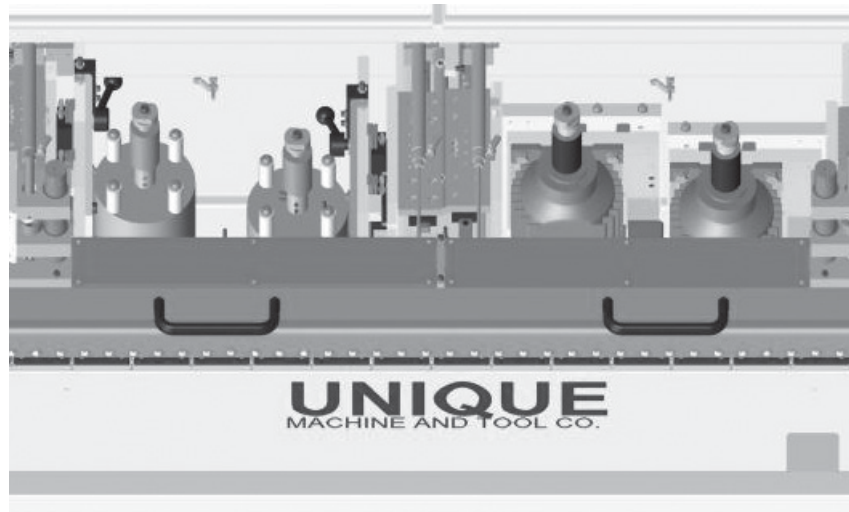

2008 Version 4.1

TECHNICAL NOTES

6" RAISED PANEL PROFILES

FOR MODELS 2750, 3250 336-4 & 4500 SERIES

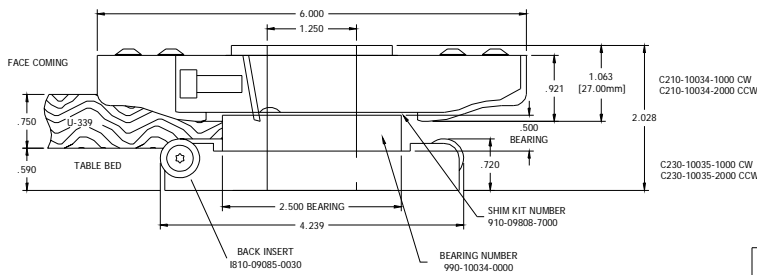

WITH BACK CUTTER

**NO BACK CUTTER
W/ SUPPORT BEARING**

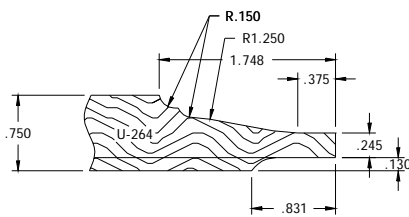
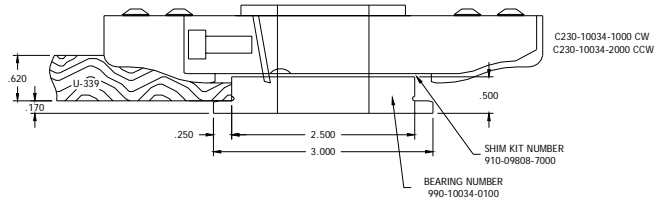

U264 INSERT NUMBER
I810-09808-1400 CW
I810-09808-2400 CCW

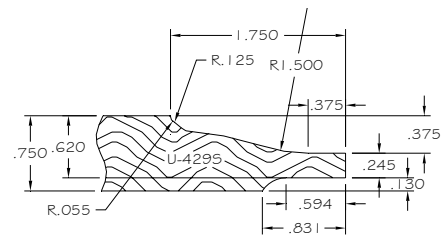

U429S INSERT NUMBER
I810-09808-1110 CW
I810-09808-2110 CCW

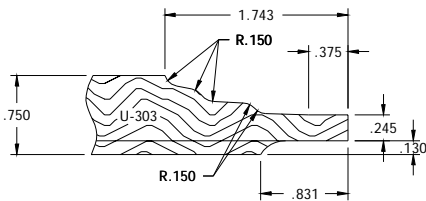

U303 INSERT NUMBER
I810-09808-1700 CW
I810-09808-2700 CCW

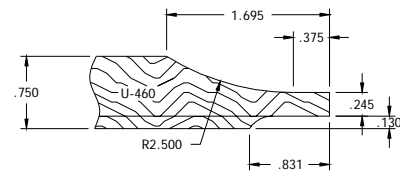

U460 INSERT NUMBER
I810-09808-1500 CW
I810-09808-2500 CCW

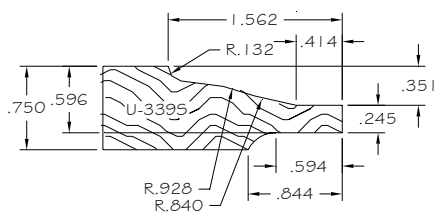

U339S INSERT NUMBER
I810-30283-1000 CW
I810-30283-2000 CCW

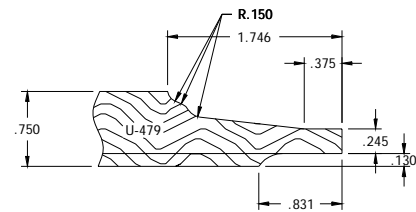

U479 INSERT NUMBER
I810-09808-1300 CW
I810-09808-2300 CCW

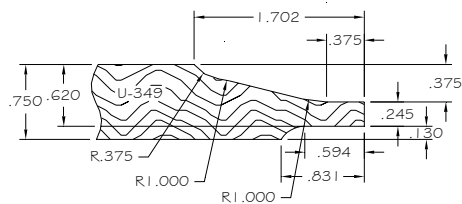

U349 INSERT NUMBER
I810-09808-1800 CW
I810-09808-2800 CCW

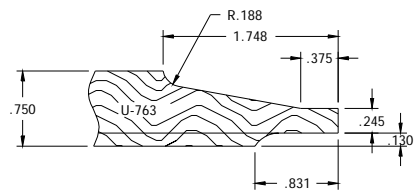

U763 INSERT NUMBER
I810-09808-1000 CW
I810-09808-2000 CCW

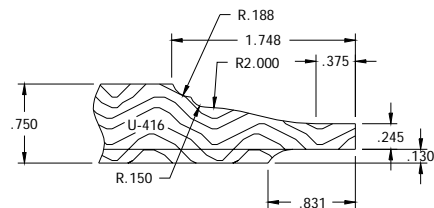

U416 INSERT NUMBER
I810-09808-2600 CCW

RAISED PANEL PROFILES

2008 Version 4.1

FOR MODELS 2750, 3250 336-4 & 4500 SERIES

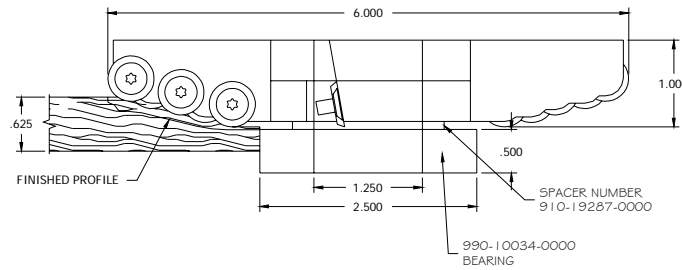

CUTTER SET NUMBER
C230-19287-7100
CONSISTING OF:
1- (3 INSERT) CUTTER NUMBER
C230-19287-0200
1- (2 INSERT) CUTTER NUMBER
C230-19287-0300

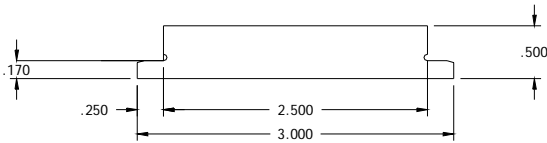

SUPPORT BEARING NUMBER
C990-10034-0100 CW/CCW
SUPPORT BEARING
RECOMMENDED WHEN NO
BACK CUTTER IS USED WITH
PANEL SET

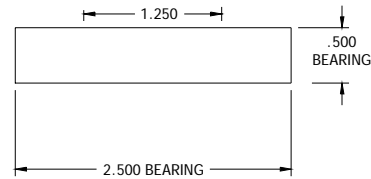

RUB BEARING NUMBER
C990-10034-0000 CW/CCW
RUB BEARING REQUIRED WHEN NO
TRIM CUTTER IS USED WITH
PANEL SET

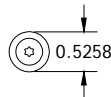

REPLACEMENT INSERT NUMBER
(15 PER CUTTER SET)
1810-09085-0030

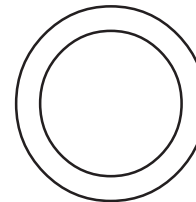

1.250" ID SHIM KIT
1810-09808-7000

- All Unique Shape & Sands come standard with floating heads for arched raised panel shaping and sanding. A support bearing is recommended when no back cutter is used on the cutter stations. Sand rub bearings are required when arching.

2008 Version 4.1

ROUGHING TOOLS

MACHINE MODEL : SHAPE & SAND

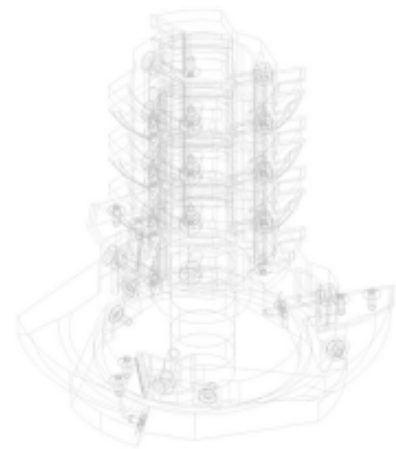
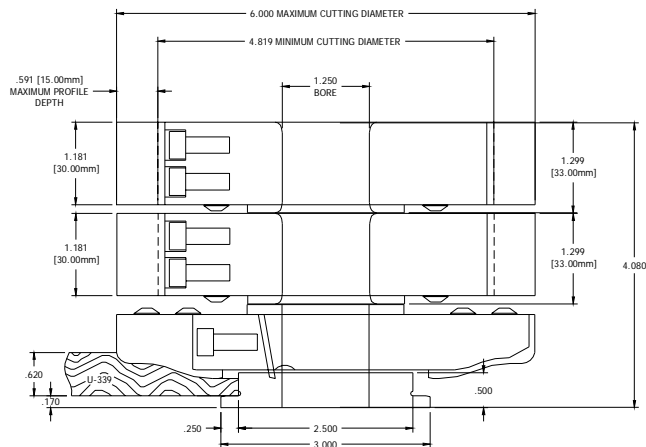

- **When machining panels on Unique Shape & Sands:**
 1. Watch Training Video prior to operation.
 2. Setting the jump cope tool is critical for quality production. Please refer to the User's Manual.
 3. **SANDING SETUP:** Cut the material first with the sand station all the way back so it will not contact the material. E-Stop the machine when the profiled material is completely in front of the sand stations. Position the sand tool towards the material until it makes contact. Make final adjustments and record that position for that profile for future reference.

- All Unique Shape & Sands come standard with floating heads for arched raised panel shaping and sanding. All Unique Shape & Sand machines are shipped without tooling. Customer tooling will be setup on new machine orders if tooling is recieved at Unique one week prior to machine delivery date.

Always install inserts using proper torque rating for tool.

MACHINE MODEL : SHAPE & SAND

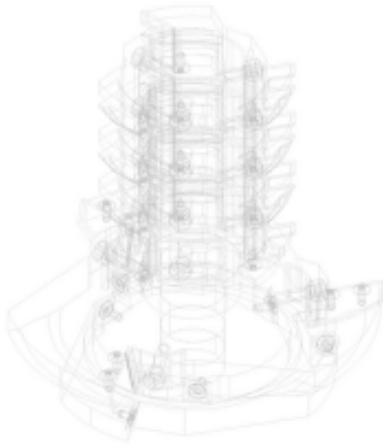

**TYPICAL SHAPE AND SAND SETUP
FOR EDGE DETAILS**

CCW Edge Sander

CW Edge Sander

CW Edge Finisher

CCW Edge Rougher

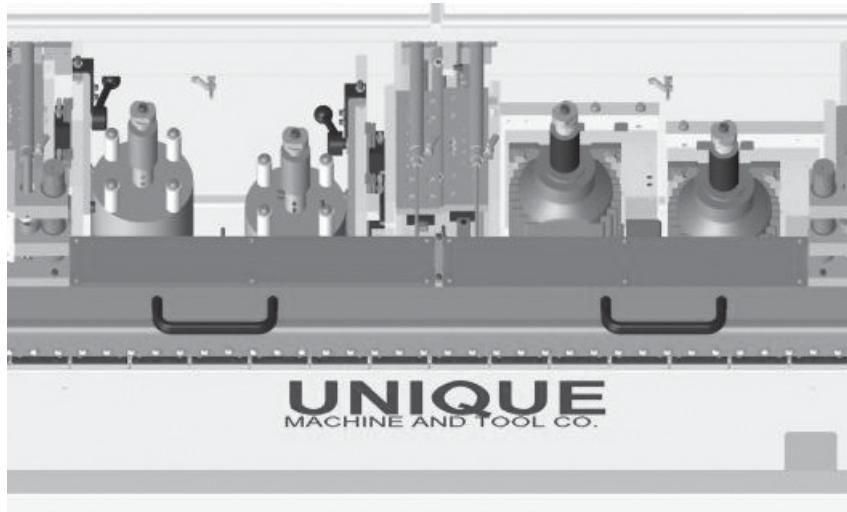

2008 Version 4.1

TECHNICAL NOTES

6" GREAT-LOC SG® EDGE DETAIL PROFILES



FOR MODELS 3250 336-4 & 4500 SERIES

STANDARD # 1 EDGE DETAIL PROFILES

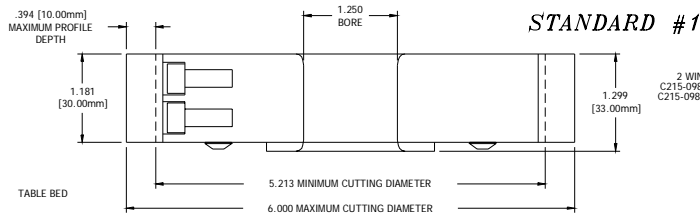

2 WING HEAD
C215-09854-1000 CW
C215-09854-2000 CCW

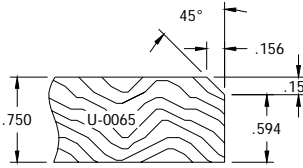
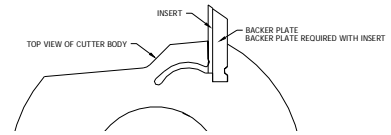

U0065 INSERT NUMBER
I816-09820-2000 CCW
BACKER NUMBER
I850-09820-2000 CCW

U0230 INSERT NUMBER
I816-09838-2000 CCW
BACKER NUMBER
I850-09838-2000 CCW

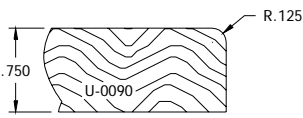
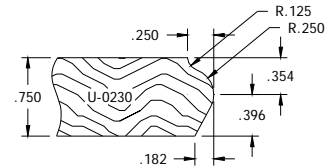

U0090 INSERT NUMBER
I816-09844-2000 CCW
BACKER NUMBER
I850-09844-2000 CCW

U0340 INSERT NUMBER
I816-09818-2000 CCW
BACKER NUMBER
I850-09818-2000 CCW

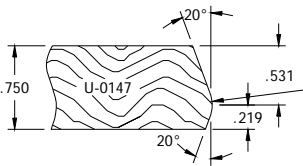

U0147 INSERT NUMBER
I816-09817-2000 CCW
BACKER NUMBER
I850-09817-2000 CCW

U0358 INSERT NUMBER
I816-09839-2000 CCW
BACKER NUMBER
I850-09839-2000 CCW

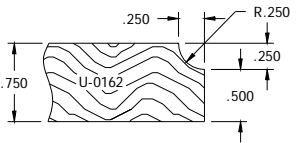
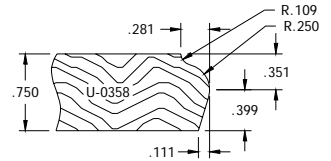

U0162 INSERT NUMBER
I816-09821-2000 CCW
BACKER NUMBER
I850-09821-2000 CCW

U0360 INSERT NUMBER
I816-09843-2000 CCW
BACKER NUMBER
I850-09843-2000 CCW

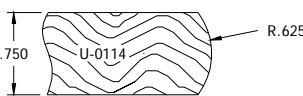
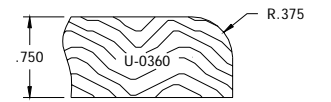

U0114 INSERT NUMBER
I816-09815-2000 CCW
BACKER NUMBER
I850-09815-2000 CCW

U0644 INSERT NUMBER
I816-09819-2000 CCW
BACKER NUMBER
I850-09819-2000 CCW

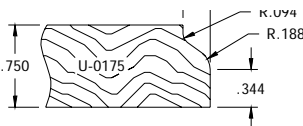
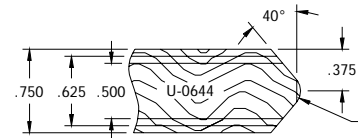

U0175 INSERT NUMBER
I816-09840-2000 CCW
BACKER NUMBER
I850-09840-2000 CCW

U0677 INSERT NUMBER
I816-09823-2000 CCW
BACKER NUMBER
I850-09823-2000 CCW

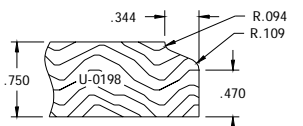
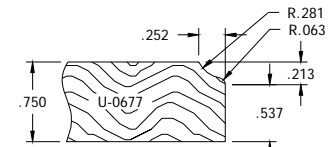

U0198 INSERT NUMBER
I816-09830-2000 CCW
BACKER NUMBER
I850-09830-2000 CCW

U0860 INSERT NUMBER
I816-09814-2000 CCW
BACKER NUMBER
I850-09814-2000 CCW

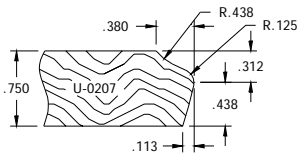
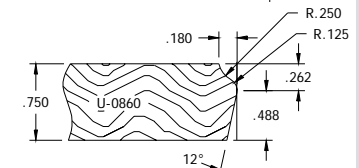

U0207 INSERT NUMBER
I816-09837-2000 CCW
BACKER NUMBER
I850-09837-2000 CCW

U4444 INSERT NUMBER
I816-09832-2000 CCW
BACKER NUMBER
I850-09832-2000 CCW

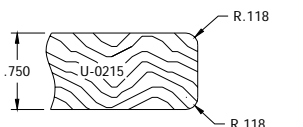

U0215 INSERT NUMBER
I816-09816-2000 CCW
BACKER NUMBER
I850-09816-2000 CCW

U0870 INSERT NUMBER
I816-09822-2000 CCW
BACKER NUMBER
I850-09822-2000 CCW

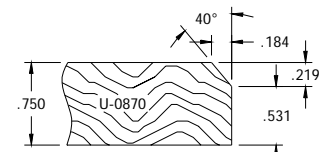

2008 Version 4.1

4232 E. Magnolia St., Phoenix, Arizona 85034 U.S.A.

PH: (602)470-1911 Fax: (602)470-1916

Website: www.uniquemachine.com

Email: tooling@uniquemachine.com

FOR MODELS 3250 336-4 & 4500 SERIES



CLIMB CUT VERSION
FOR STD# 1 CUTTERS
Select profiles shown. For part number of profile not pictured below please contact the Unique Tooling Department

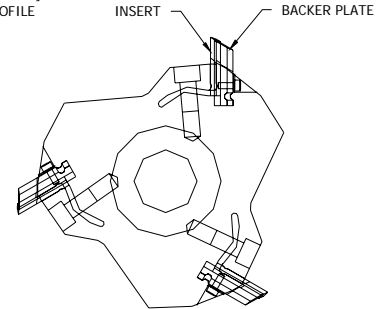
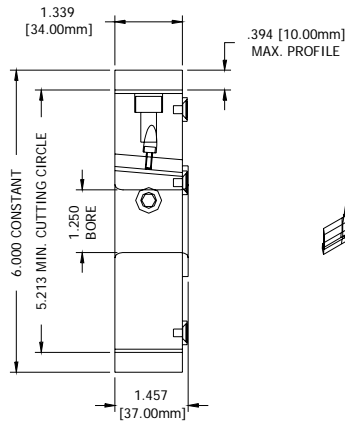

STANDARD #1
CUTTER NUMBER
216-21820-1000
3 WINGS
CLIMB CUTTING
PART WITH PROFILE UP

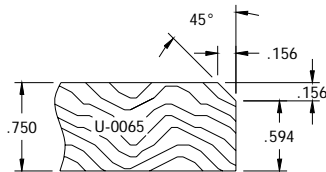

U0065 INSERT NUMBER
I816-18427-1000 CW
BACKER NUMBER
I850-18427-1000 CW

U0360 INSERT NUMBER
I816-17186-1000 CW
BACKER NUMBER
I850-17186-1000 CW

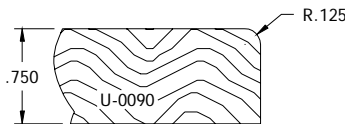

U0090 INSERT NUMBER
I816-16001-1000 CW
BACKER NUMBER
I850-16001-1000 CW

U0870 INSERT NUMBER
I816-18118-1000 CW
BACKER NUMBER
I850-18118-1000 CW

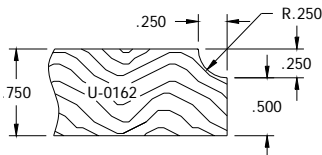
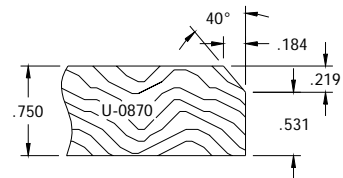

U0162 INSERT NUMBER
I816-19021-1000 CW
BACKER NUMBER
I850-19021-1000 CW

U4444 INSERT NUMBER
I816-18119-1000 CW
BACKER NUMBER
I850-18119-1000 CW

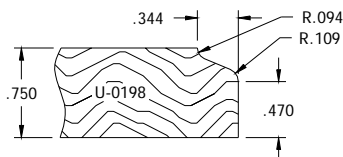

U0198 INSERT NUMBER
I816-18426-1000 CW
BACKER NUMBER
I850-18426-1000 CW

2008 Version 4.1

STANDARD # 1 EDGE DETAIL PROFILES

6" GREAT-LOC SG® EDGE DETAIL PROFILES



FOR MODELS 3250 336-4 & 4500 SERIES

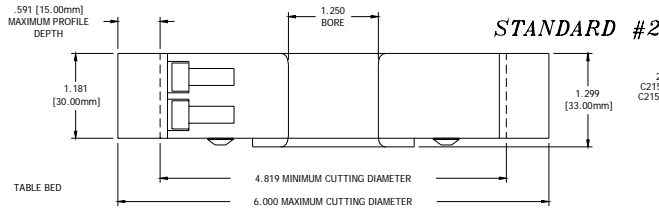

2 WING HEAD
C215-09853-1000 CCW
C215-09853-2000 CCW

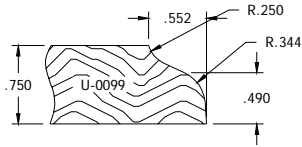
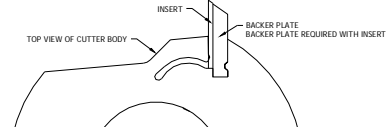

U0099 INSERT NUMBER
I816-09828-2000 CCW
BACKER NUMBER
I850-09828-2000 CCW

U255 INSERT NUMBER
I816-09849-2000 CCW
BACKER NUMBER
I850-09849-2000 CCW

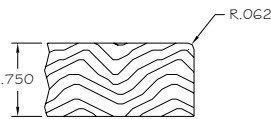
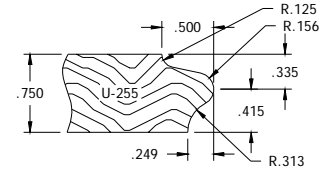

U063 INSERT NUMBER
I816-32296-2000 CCW
BACKER NUMBER
I850-32296-2000 CCW

U284 INSERT NUMBER
I816-09846-2000 CCW
BACKER NUMBER
I850-09846-2000 CCW

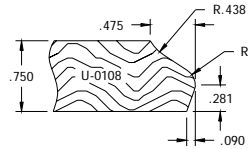
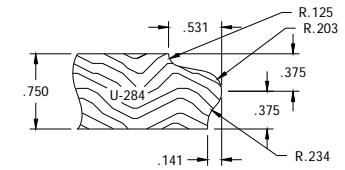

U0108 INSERT NUMBER
I816-09826-2000 CCW
BACKER NUMBER
I850-09826-2000 CCW

U0285 INSERT NUMBER
I816-09835-2000 CCW
BACKER NUMBER
I850-09835-2000 CCW

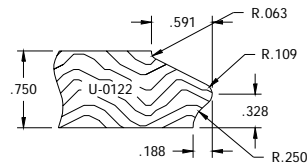
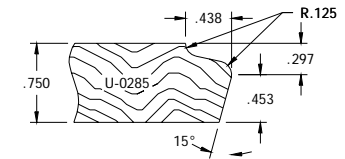

U0122 INSERT NUMBER
I816-09824-2000 CCW
BACKER NUMBER
I850-09824-2000 CCW

U313 INSERT NUMBER
I816-18428-2000 CCW
BACKER NUMBER
I850-18428-2000 CCW

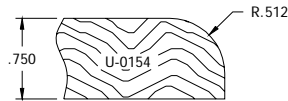
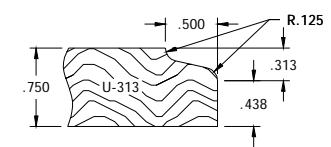

U0154 INSERT NUMBER
I816-09841-2000 CCW
BACKER NUMBER
I850-09841-2000 CCW

U314 INSERT NUMBER
I816-09848-2000 CCW
BACKER NUMBER
I850-09848-2000 CCW

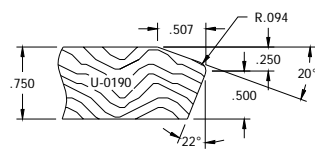
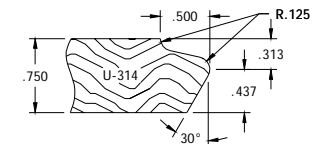

U0190 INSERT NUMBER
I816-09847-2000 CCW
BACKER NUMBER
I850-09847-2000 CCW

U381 INSERT NUMBER
I816-09827-2000 CCW
BACKER NUMBER
I850-09827-2000 CCW

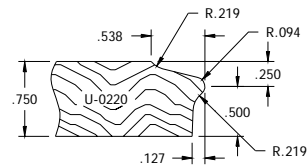
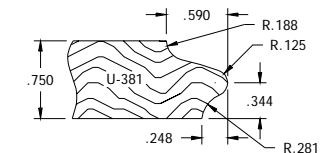

U0220 INSERT NUMBER
I816-09845-2000 CCW
BACKER NUMBER
I850-09845-2000 CCW

U0885 INSERT NUMBER
I816-09842-2000 CCW
BACKER NUMBER
I850-09842-2000 CCW

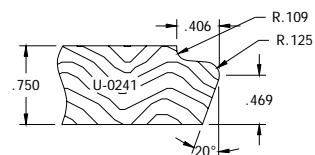
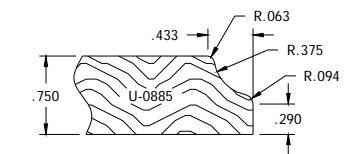

U0241 INSERT NUMBER
I816-09836-2000 CCW
BACKER NUMBER
I850-09836-2000 CCW

STANDARD # 2 EDGE DETAIL PROFILES

2008 Version 4.1

4232 E. Magnolia St., Phoenix, Arizona 85034 U.S.A.

PH: (602)470-1911 Fax: (602)470-1916

Website: www.uniquemachine.com

Email: tooling@uniquemachine.com

FOR MODELS 3250 336-4 & 4500 SERIES



CLIMB CUT VERSION
FOR STD# 2 CUTTERS
Select profiles shown. For part number of profile not pictured below please contact the Unique Tooling Department

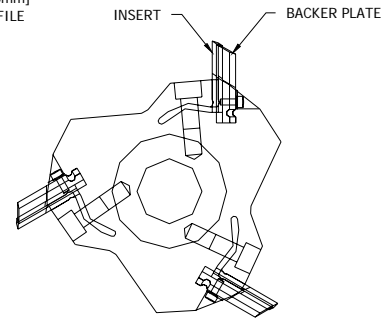
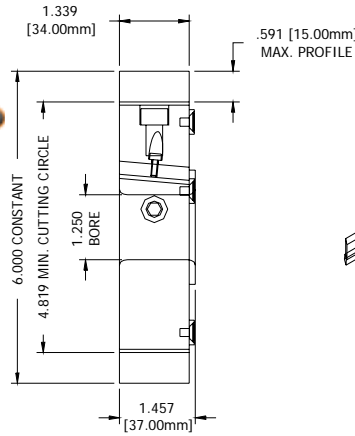

STANDARD #2
CUTTER NUMBER
216-21822-1000
3 WINGS
CLIMB CUTTING
PART WITH PROFILE UP

2008 Version 4.1

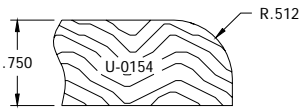

U0154 INSERT NUMBER
I816-20476-1000 CW
BACKER NUMBER
I850-20476-1000 CW

U255 INSERT NUMBER
I816-18120-1000 CW
BACKER NUMBER
I850-18120-1000 CW

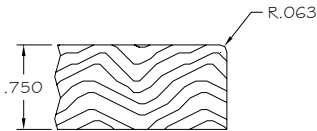
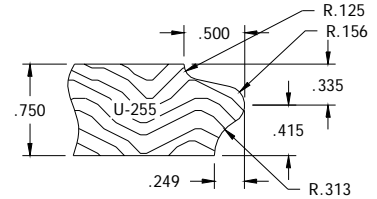

U063 INSERT NUMBER
I816-32295-2000 CCW
BACKER NUMBER
I850-32295-2000 CCW

U0285 INSERT NUMBER
I816-16003-1000 CW
BACKER NUMBER
I850-16003-1000 CW

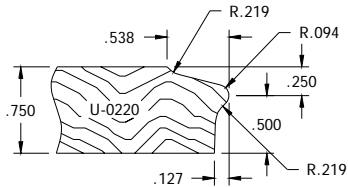
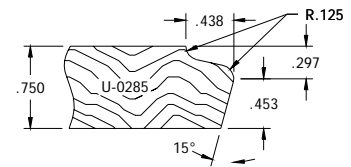

U0220 INSERT NUMBER
I816-18373-1000 CW
BACKER NUMBER
I850-18373-1000 CW

U313 INSERT NUMBER
I816-16617-1000 CW
BACKER NUMBER
I850-16617-1000 CW

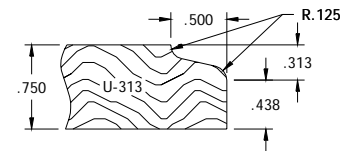

STANDARD # 2 EDGE DETAIL PROFILES

6" GREAT-LOC SG® EDGE DETAIL PROFILES

FOR MODELS 3250 336-4 & 4500 SERIES

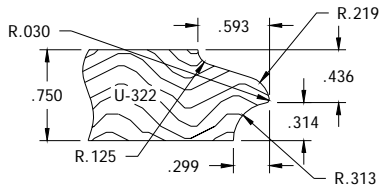
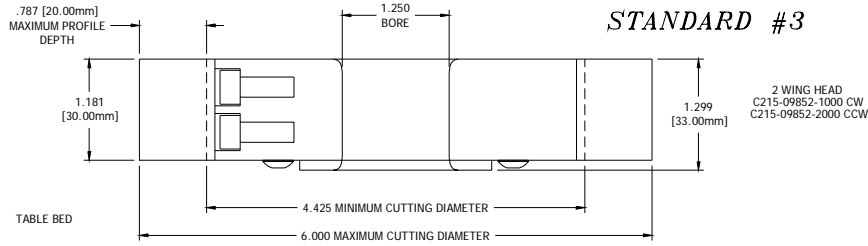

U322 INSERT NUMBER
I816-09825-2000 CCW
BACKER NUMBER
I850-09825-2000 CCW

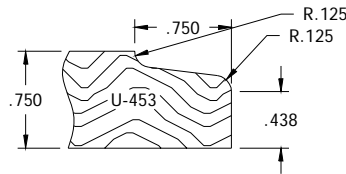

U453 INSERT NUMBER
I816-09834-2000 CCW
BACKER NUMBER
I850-09834-2000 CCW

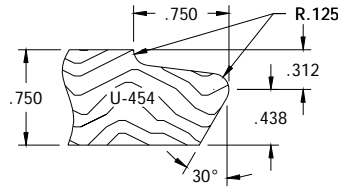

U454 INSERT NUMBER
I816-09833-2000 CCW
BACKER NUMBER
I850-09833-2000 CCW



**CLIMB CUT VERSION
AVAILABLE**



STANDARD # 3 EDGE DETAIL PROFILES

2008 Version 4.1

FOR MODELS 2752, 2753, 2710 & 2722

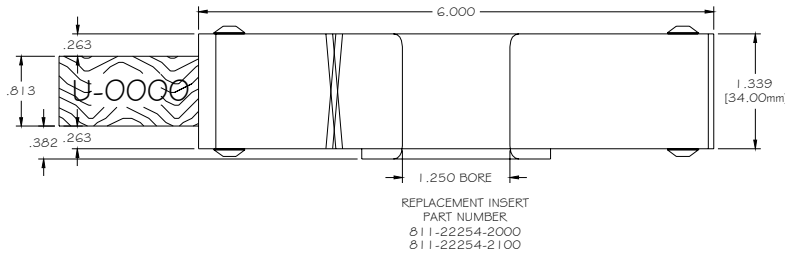

CONVENTIONAL CUTTING
CUTTER NUMBER
211-22254-2000

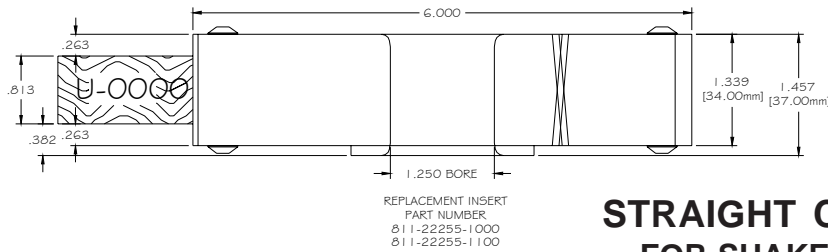

CLIMB CUTTING
CUTTER NUMBER
211-22255-1000

**STRAIGHT CUTTERS
FOR SHAKER EDGE**

2008 Version 4.1

HOGGER TOOLS

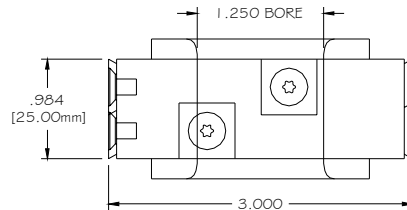

3" OD HOGGER FOR 2752, 2753, 2710 & 2722
C230-14545-0000

REPLACEMENT INSERT NUMBER
I331889

6" SG2 CUTTERS PROFILE DOWN

FOR UNIQUE SHAPE & SAND MODELS

GREAT-LOC SG POSITIVE CLAMPING

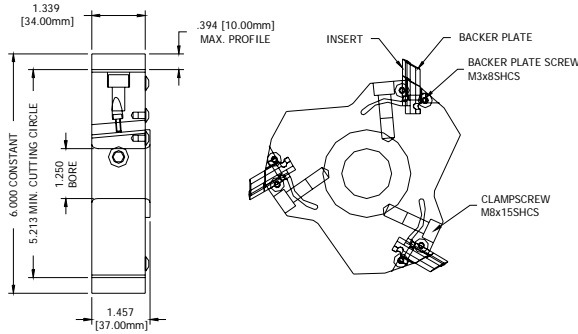

STANDARD #1
CUTTER NUMBER
216-21808-1000
3 WINGS
CLIMB CUTTING
PART WITH PROFILE DOWN

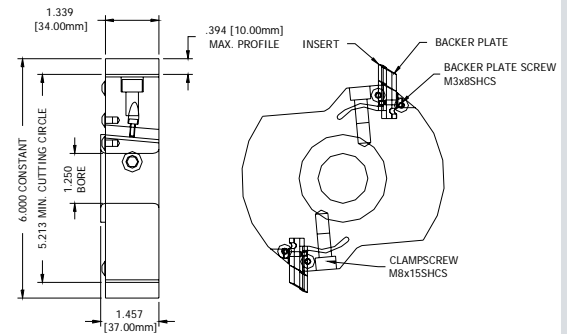

STANDARD #1
CUTTER NUMBER
216-21809-2000
2 WINGS

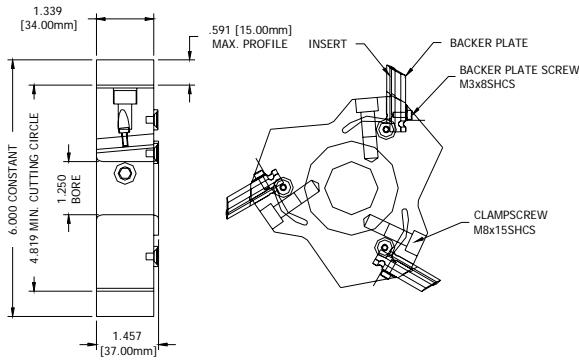

STANDARD #2
CUTTER NUMBER
216-21810-1000
3 WINGS
CLIMB CUTTING

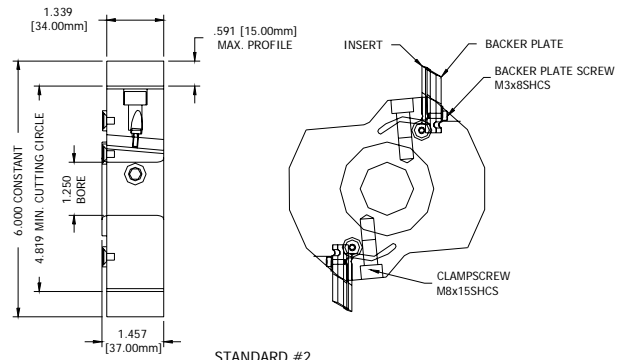

STANDARD #2
CUTTER NUMBER
216-21811-2000
2 WINGS
CONVENTIONAL CUTTING
PART WITH PROFILE DOWN

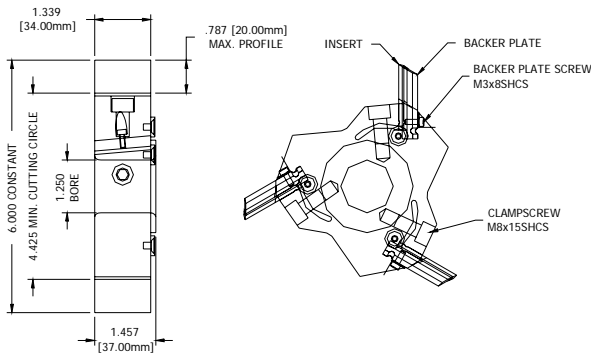

STANDARD #3
CUTTER NUMBER
216-21812-1000
3 WINGS
CLIMB CUTTING
PART WITH PROFILE DOWN

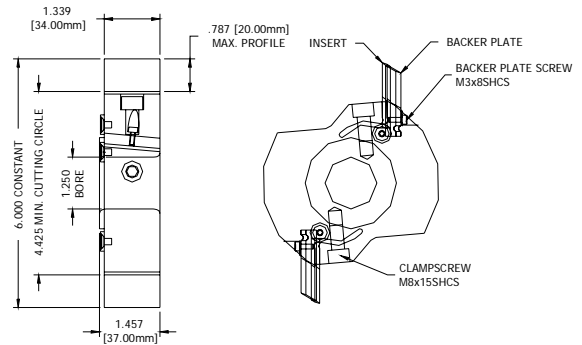

STANDARD #3
CUTTER NUMBER
216-21813-2000
2 WINGS
CONVENTIONAL CUTTING
PART WITH PROFILE DOWN

**CAN ACCOMMODATE ALL PROFILES ON EDGE DETAIL PAGES
PLEASE CALL FOR INFORMATION, QUOTATION & PART NUMBER**

2008 Version 4.1

FOR UNIQUE SHAPE & SAND MODELS

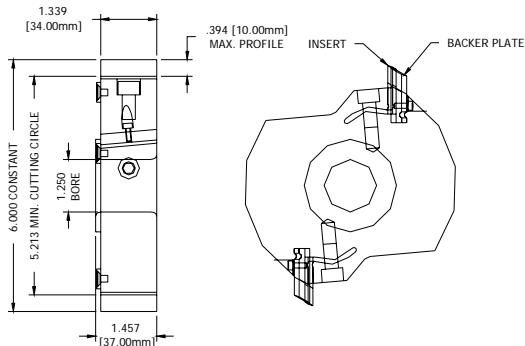

STANDARD #1
CUTTER NUMBER
216-21821-2000
2 WINGS
CONVENTIONAL CUTTING
PART WITH PROFILE UP

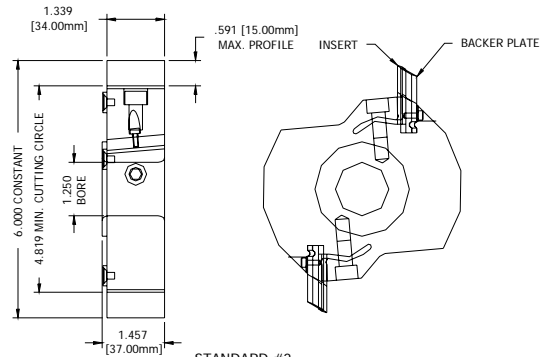

STANDARD #2
CUTTER NUMBER
216-21823-2000
2 WINGS
CONVENTIONAL CUTTING
PART WITH PROFILE UP

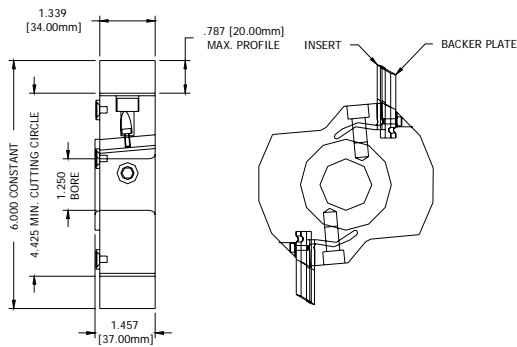

STANDARD #3
CUTTER NUMBER
216-21825-2000
2 WINGS
CONVENTIONAL CUTTING
PART WITH PROFILE UP

**CAN ACCOMMODATE ALL PROFILES ON EDGE DETAIL PAGES
PLEASE CALL FOR INFORMATION, QUOTATION & PART NUMBER**

2008 Version 4.1

GREAT-LOC SG POSITIVE CLAMPING

**TOOLING
FOR
MODELS**



2722



STANDARD ENTRY DOOR CUTTERS

FOR MODEL 2710, 2720, 2722

THIS IS APPLICATION SPECIFIC TOOLING
PLEASE CONTACT THE UNIQUE TOOLING
DEPARTMENT FOR QUOTATION

CUTTER CAN BE FLIPPED OVER
AND RAN CW OR CCW

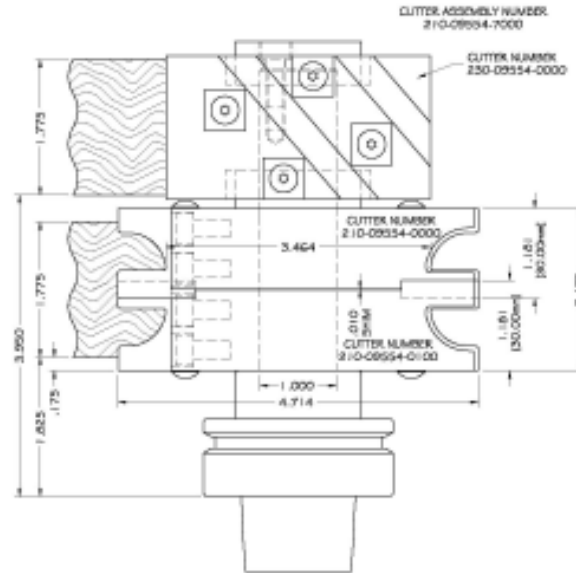

CUTTER CAN BE FLIPPED OVER
AND RAN CW OR CCW

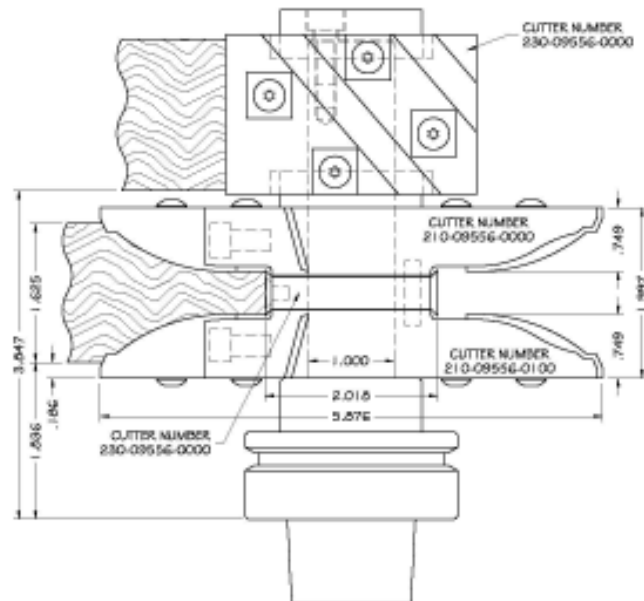
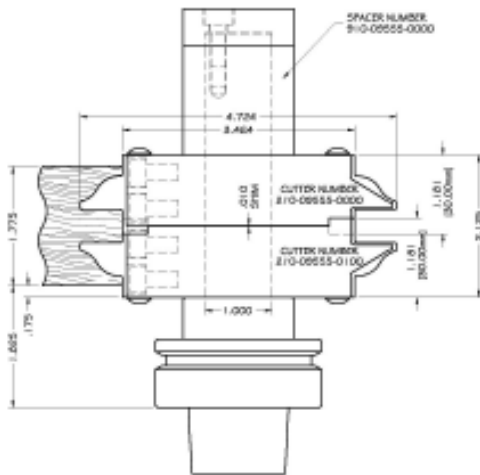

STANDARD ENTRY DOOR CUTTERS

2008 Version 4.1



**PROFILE SANDING
FOR UNIQUE SHAPE & SAND MODELS**

FOR UNIQUE SHAPE & SAND MODELS

ARMINIUS PROFILE SANDING



PROFILE NUMBER	TOOL PART NUMBER	ABRASIVE LOAD PART NUMBER
PANELS		
U-303	AR-303-PANEL	AR-303-LD-GRIT
U-339S	AR-339S-PANEL	AR-339S-LD-GRIT
U-416	AR-416-PANEL	AR-416-LD-GRIT
U-429S	AR-429S-PANEL	AR-429S-LD-GRIT
U-460	AR-460-PANEL	AR-460-LD-GRIT
EDGE DETAILS		
U-090	AR-090-EDGE	AR-090-LD-GRIT
U-190	AR-190-EDGE	AR-190-LD-GRIT
U-198	AR-198-EDGE	AR-198-LD-GRIT
U-220	AR-220-EDGE	AR-220-LD-GRIT
U-313	AR-313-EDGE	AR-313-LD-GRIT
U-314	AR-314-EDGE	AR-314-LD-GRIT
U-360	AR-360-EDGE	AR-360-LD-GRIT
U-4444	AR-4444-EDGE	AR-4444-LD-GRIT

WHEN ORDERING ABRASIVE LOADS, SUBSTITUTE "GRIT" FOR THE ABRASIVE GRIT REQUIRED I.E. AR-460-LD-150 : AR-460-LD-180

**For profile numbers not listed or to order custom profiles
please contact the Unique Tooling Department**

PROFILE SANDING TOOLS

2008 Version 4.1



ROSALES PROFILE SANDING

PROFILE NUMBER	TOOL PART NUMBER	ABRASIVE LOAD PART NUMBER
PANELS		
U-303	RS-303-PANEL	RS-303-LD-GRIT
U-339	RS-339-PANEL	RS-339-LD-GRIT
U-416	RS-416-PANEL	RS-416-LD-GRIT
U-429	RS-429-PANEL	RS-429-LD-GRIT
U-460	RS-460-PANEL	RS-460-LD-GRIT
EDGE DETAILS		
U-090	RS-0090-EDGE	RS-0090-LD-GRIT
U-190	RS-190-EDGE	RS-190-LD-GRIT
U-198	RS-0198-EDGE	RS-0198-LD-GRIT
U-220	RS-220-EDGE	RS-220-LD-GRIT
U-313	RS-313-EDGE	RS-313-LD-GRIT
U-314	RS-314-EDGE	RS-314-LD-GRIT
U-360	RS-360-EDGE	RS-360-LD-GRIT
U-4444	RS-4444-EDGE	RS-4444-LD-GRIT

WHEN ORDERING ABRASIVE LOADS, SUBSTITUTE "GRIT" FOR THE ABRASIVE GRIT REQUIRED I.E. RS-460-LD-150 : RS-460-LD-180

**For profile numbers not listed
please contact the Unique Tooling Department**

2008 Version 4.1

PROFILE SANDING TOOLS

MACHINE MODEL : ALL 250'S BUILT AFTER 1993

Custom or other than standard arch height templates are also available. Custom templates can be designed by our Engineers.

A template set consists of 4 panel and 4 matching rail templates.

ARCHED RAIL & PANEL TEMPLATE SETS

CATHEDRAL ARCH Style Doors

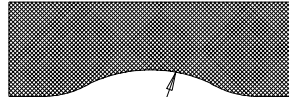
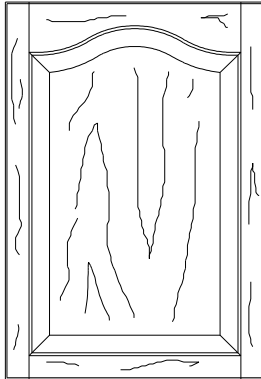

1-1/8" Rise, UNIQUE™ Standard Style

P/N 998800 3", 4", 5", 6"

P/N 999812 7", 8", 9", 10"

P/N 998900 11", 12", 13", 14"

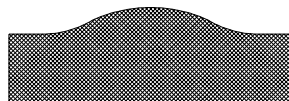

2" Rise, UNIQUE™ Standard Style

P/N 999802 3", 4", 5", 6"

P/N 100009 7", 8", 9", 10"

P/N 100010 11", 12", 13", 14"

Size is Radius of Arch

OVAL / EYEBROW Style Doors

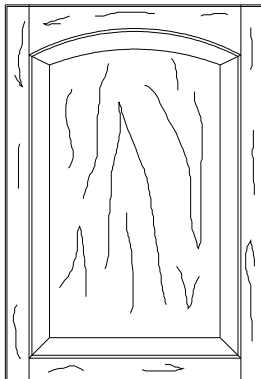

1-1/8" Rise, UNIQUE™ Standard Style

P/N 998810 4", 5", 6", 7"

P/N 998820 8", 9", 10", 11"

P/N 998830 12", 13", 14", 15"

P/N 998840 16", 17", 18", 19"

P/N 998850 20", 21", 22", 23"

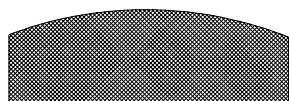

2" Rise, UNIQUE™ Standard Style

P/N 100017 8", 9", 10", 11"

P/N 100018 12", 13", 14", 15"

P/N 100019 16", 17", 18", 19"

Size is Panel Width

COUNTRY FRENCH Style Doors

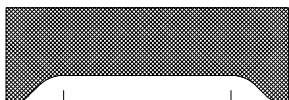
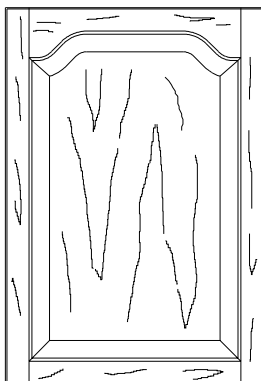

1-1/8" Rise, UNIQUE™ Standard Style

P/N 998860 2", 3", 4", 5"

P/N 998870 6", 7", 8", 9"

P/N 100032 10", 11", 12", 13"

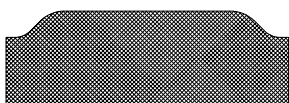

2" Rise, UNIQUE™ Standard Style

P/N 100020 2", 3", 4", 5"

P/N 100021 6", 7", 8", 9"

P/N 100022 10", 11", 12", 13"

Size is Top of Flat Area

Each Model 290 template set contains the complete list of Lexan templates below for Arch or Eyebrow, 1 Aluminium mounting bracket and four nylon template fastening screws.

Cathedral Template Set - ORDER # 999313

Oval / Eyebrow Template Set - ORDER # 999030

CATHEDRAL ARCH Style Doors

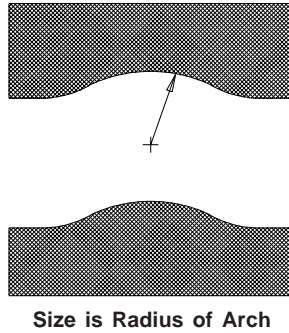
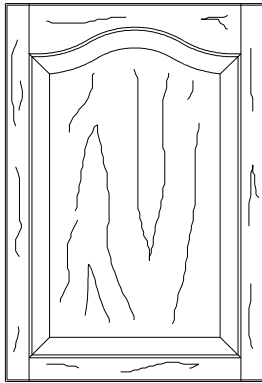

UNIQUE™ 290 Standard Style

- P/N 290400 8" Wide Door / 4.5" R
- P/N 290401 9" Wide Door / 5.25" R
- P/N 290402 10" Wide Door / 6.25" R
- P/N 290403 11" Wide Door / 7.25" R
- P/N 290404 12" Wide Door / 8.25" R
- P/N 290405 13" Wide Door / 9.5" R
- P/N 290406 14" Wide Door / 11" R
- P/N 290407 14" Wide Door / 11" R

OVAL / EYEBROW Style Doors

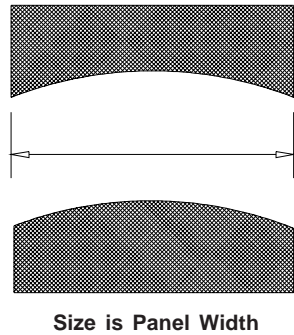
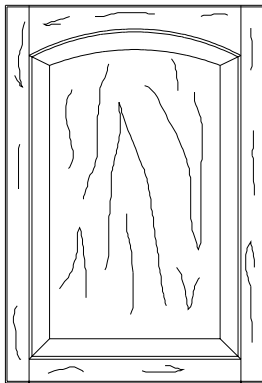

UNIQUE™ 290 Standard Style

- P/N 290216 8" Wide Door / 4.5" R
- P/N 290217 9" Wide Door / 5.25" R
- P/N 290218 10" Wide Door / 6.25" R
- P/N 290219 11" Wide Door / 7.25" R
- P/N 290220 12" Wide Door / 8.25" R
- P/N 290221 13" Wide Door / 9.5" R
- P/N 290222 14" Wide Door / 11" R
- P/N 290223 15" Wide Door / 12.5" R
- P/N 290224 16" Wide Door / 14" R
- P/N 290225 17" Wide Door / 15.5" R
- P/N 290226 18" Wide Door / 17.25" R
- P/N 290227 19" Wide Door / 19.25" R

UNIQUE™ 290 Optional Styles

- P/N 290228 20" Wide Door / 21.25" R
- P/N 290229 21" Wide Door / 23.25" R
- P/N 290230 22" Wide Door / 25.25" R
- P/N 290231 23" Wide Door / 27.5" R
- P/N 290232 24" Wide Door / 30" R

The Optional Lexan templates to the right are available but not included in the set. To order please contact the Unique Tooling Department

2008 Version 4.1

ARCHED RAIL & PANEL TEMPLATE SETS

CUSTOM TOOLING

Custom tooling orders can be engineered either from wood samples or cad drawings.
 Template orders can be engineered from cad drawings

Total lead time can vary depending on number of factors.

The typical lead time for custom tooling orders to be engineered, quoted and for Unique Machine Tool to be in possession of customer's approval prints and down payment ** is highlighted below:

- 1-3 day engineering time
- 1 week for receipt of **approval prints & down payment**
- 4 weeks for tool manufacturing
- Total lead time up to 5-6 weeks

**** 50 % down payment is required on all custom orders.**
Balance to be paid prior to tooling being shipped.

***** Estimates may vary +/- 25%**

FOR USE ONLY IF YOU CAN PROVIDE PROPER PART NUMBER AND ARE AN EXISTING CUSTOMER WHO HAS ORDERED FROM UNIQUE DIRECT BEFORE (PART NUMBER IS LASER ETCHED ON INSERT)
 FAX ORDER TO 1-602-470-1916 - YOU WILL RECEIVE AN SALES CONFIRMATION WHICH NEEDS TO BE SIGNED AND FAXED BACK TO CONFIRM ORDER.

ITEM #	QTY	INSERT NUMBER	PROFILE / DESCRIPTION
EX.	24	1810-09808-2500	U-460 PANEL PROFILE CCW
1			
2			
3			
4			
5			
6			
7			
8			
9			

CUSTOMER INFO

PAYMENT / SHIP INFO

COMPANY NAME: _____

SHIP TO: _____

CONTACT NAME: _____

PHONE: _____

METHOD OF SHIPPING: UPS GND/UPS BLUE
 (PLEASE CIRCLE) UPS ORG/UPS RED

FAX: _____

METHOD OF PAYMENT:
 (PLEASE CIRCLE) VISA/MC COD



**UNIQUE MACHINE & TOOL OFFERS
A COMPLETE
TOOLING SOLUTION**

**CALL 602-470-1911
FOR ALL
YOUR TOOLING NEEDS**

UNIQUE
MACHINE & TOOL CO.

**4232 E. Magnolia St.
Phoenix, Arizona 85034 U.S.A.**

**Website: www.uniquemachine.com
Email: tooling@uniquemachine.com**

**Phone: (602)470-1911
Fax: (602)470-1916**



**2008
SUPPLEMENTAL TOOLING
REFERENCE GUIDE
VERSION 4.1**



**STANDARD TOOLING SET
CONFIGURATIONS**

STANDARD MODEL 250 TOOLING SET

MODEL 250
STANDARD CUTTERS
The drawing shows a typical
stack for this machine model

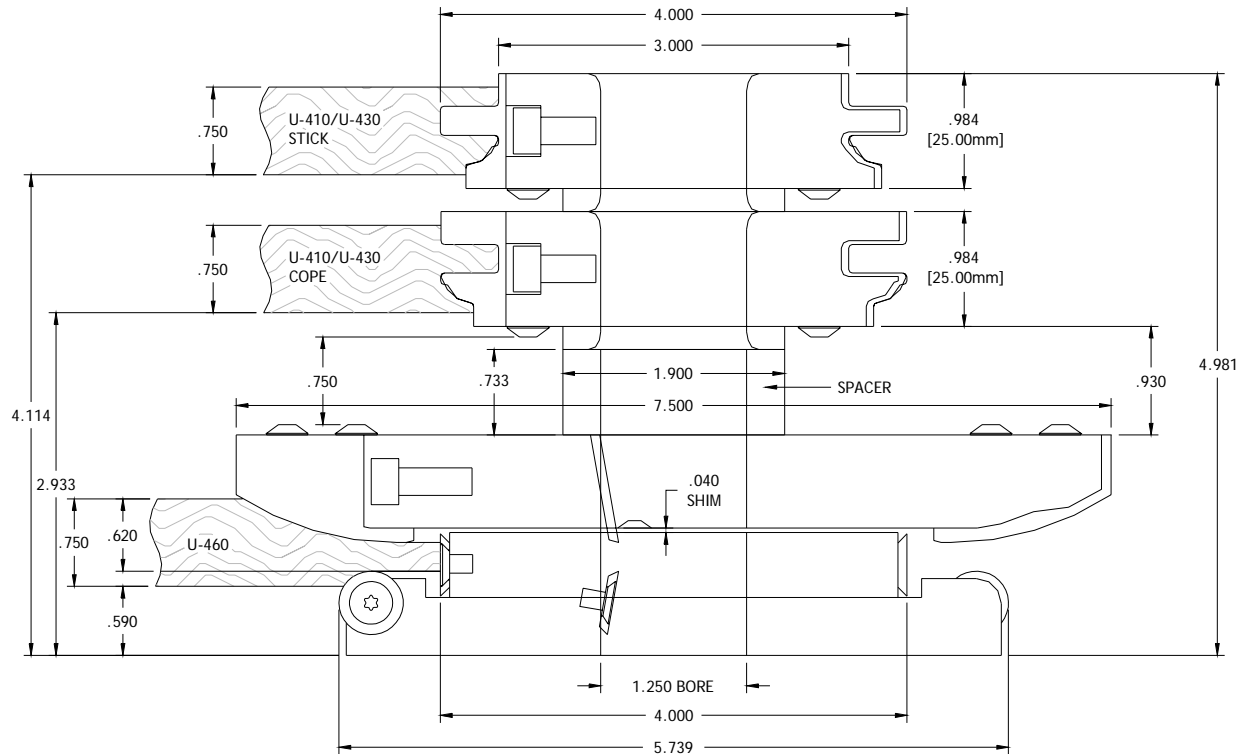
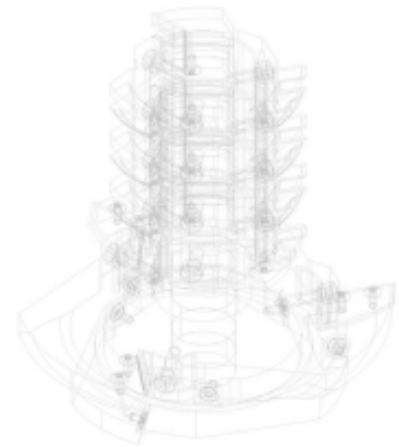

TOOLING CONFIGURATIONS

2008 Version 4.1

STANDARD MODEL 250GT2 TOOLING SET

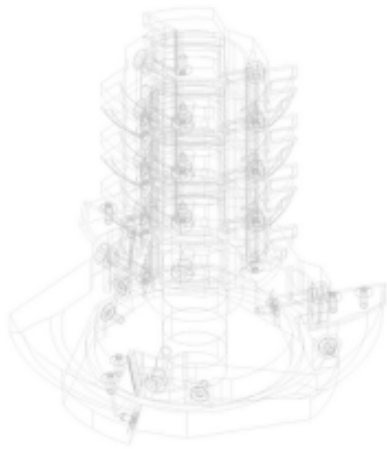

MODEL 250GT2
STANDARD CUTTERS
The drawing shows a typical
stack for this machine model



2008 Version 4.1

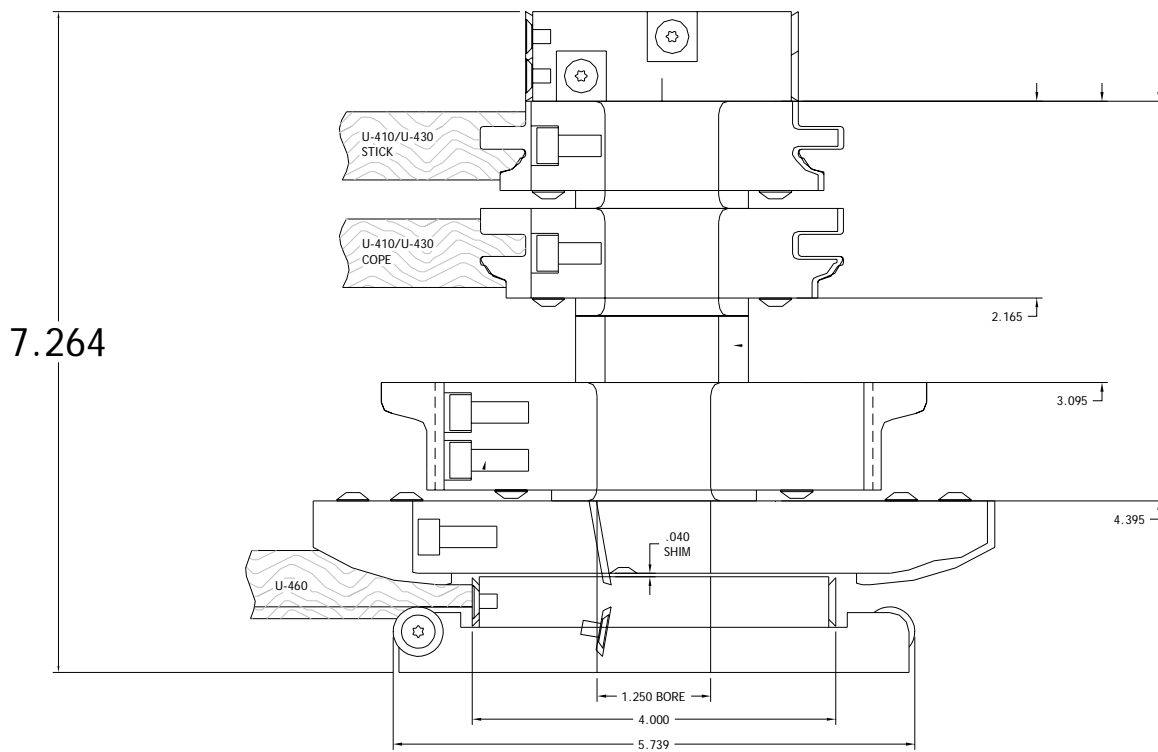

TOOLING CONFIGURATIONS

STANDARD MODEL 265-2 TOOLING SET

MODEL 265-2
STANDARD CUTTERS
The drawing shows a typical
stack for this machine model

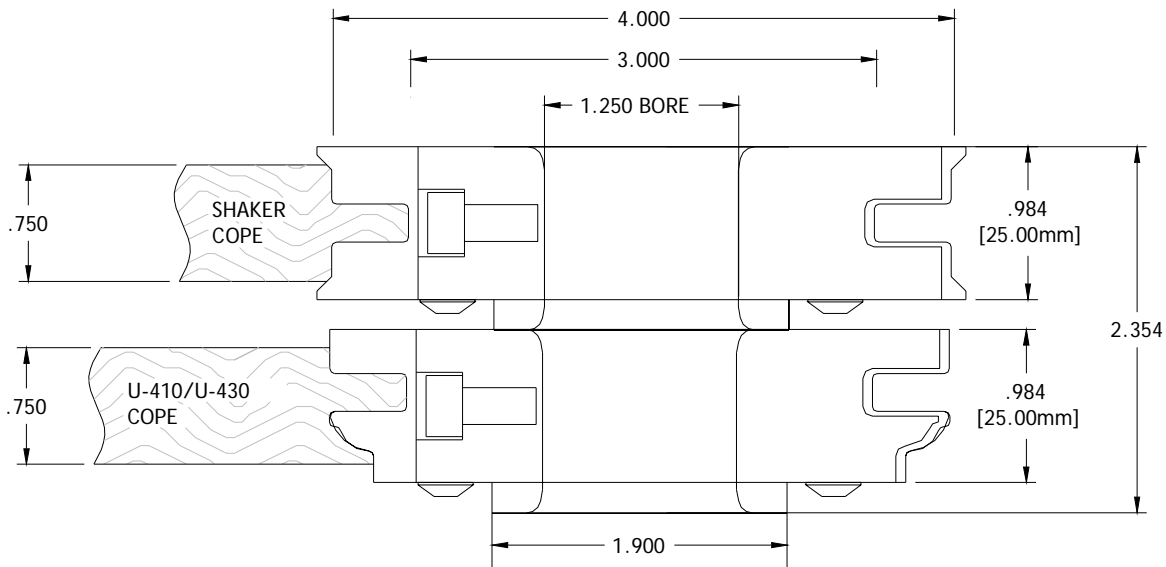
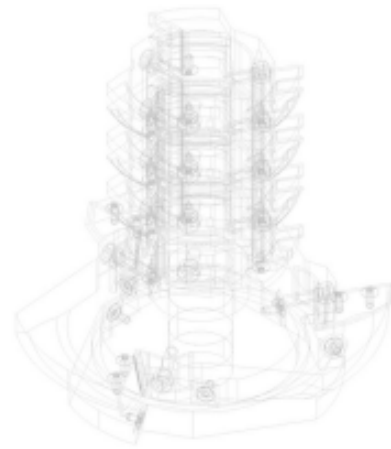

STANDARD MODEL 310 / 311 TOOLING SET

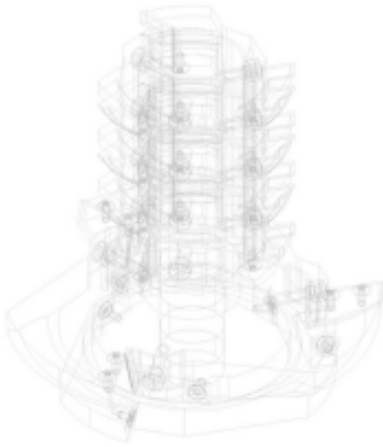

MODEL 310/311
STANDARD CUTTERS
The drawing shows a typical
stack for this machine model



2008 Version 4.1

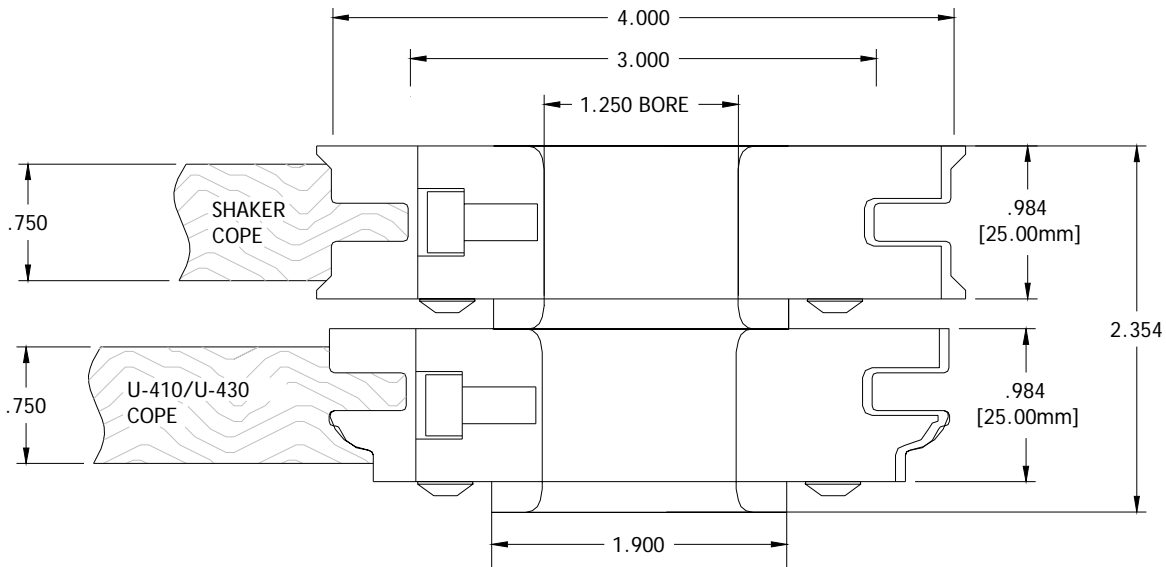

NOTE: Models 310 / 311 have two spindles, cw & ccw cutters required

TOOLING CONFIGURATIONS

STANDARD MODEL 310GT TOOLING SET

MODEL 310GT
STANDARD CUTTERS
The drawing shows a typical
stack for this machine model

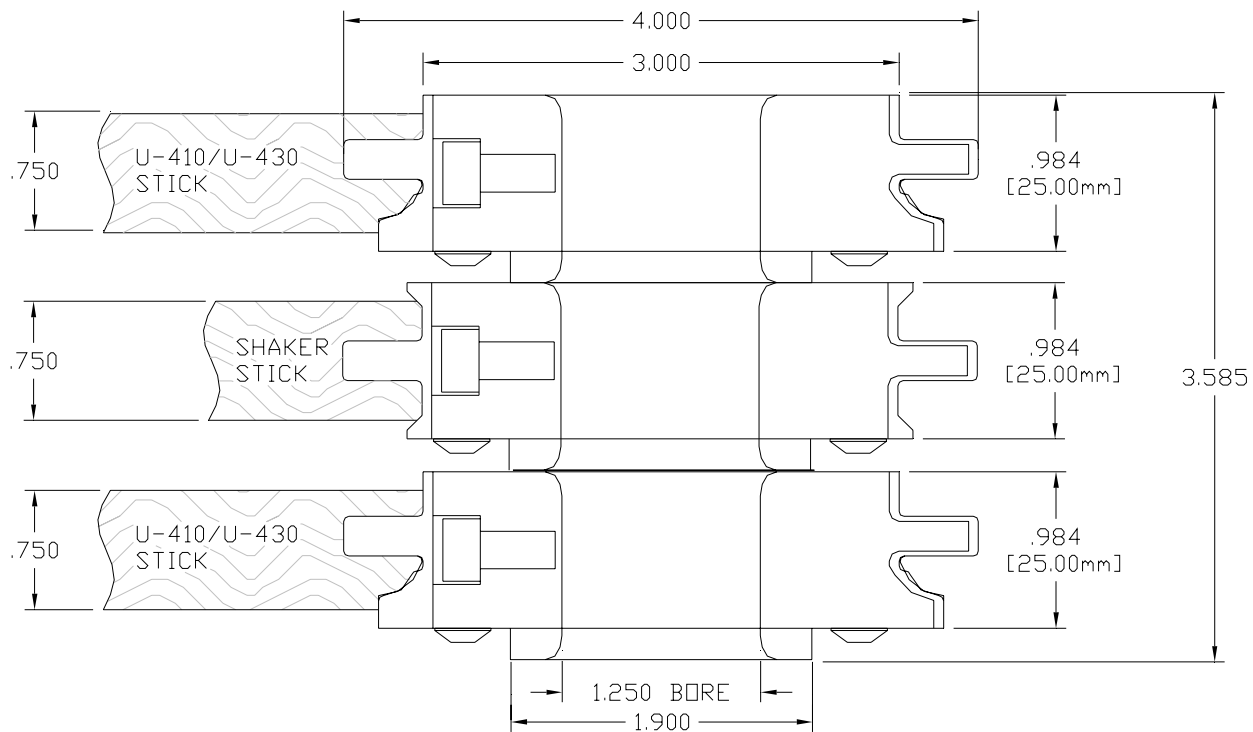
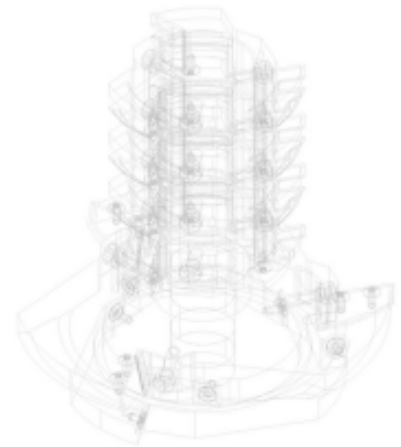

STANDARD MODEL 313 TOOLING SET

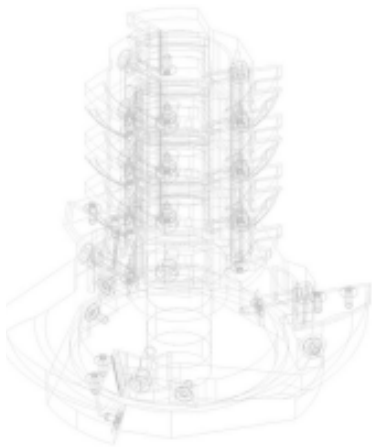

MODEL 313
STANDARD CUTTERS
The drawing shows a typical
stack for this machine model

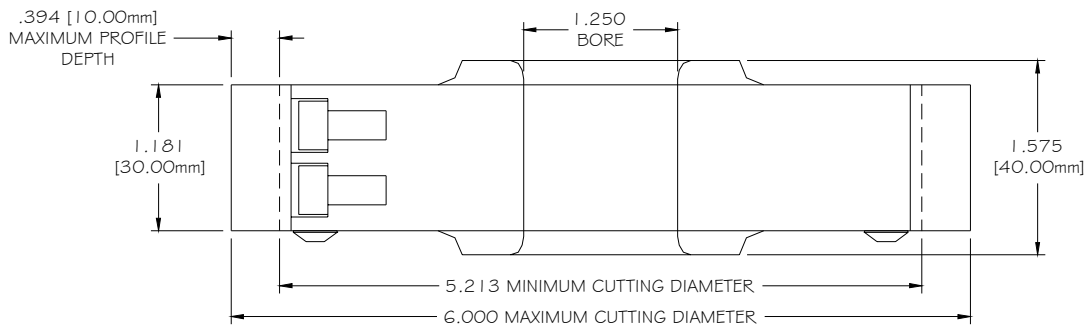

NOTE: Model 313 has two spindles, cw & ccw cutters required

2008 Version 4.1

TOOLING CONFIGURATIONS

STANDARD MODEL 313GT2 TOOLING SET

MODEL 313GT2
STANDARD CUTTERS
The drawing shows a typical
stack for this machine model

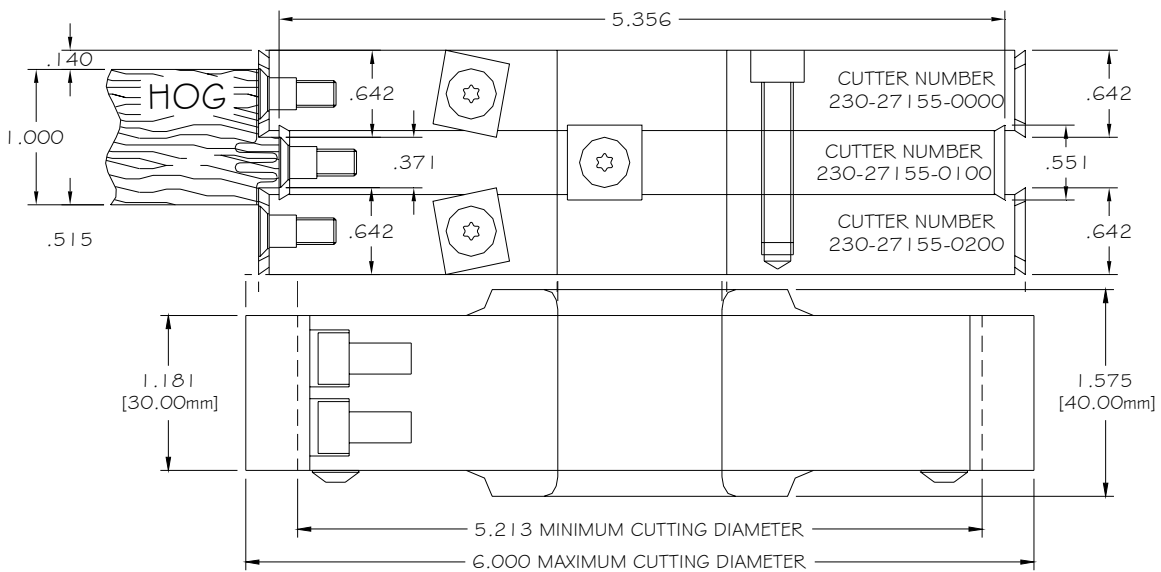
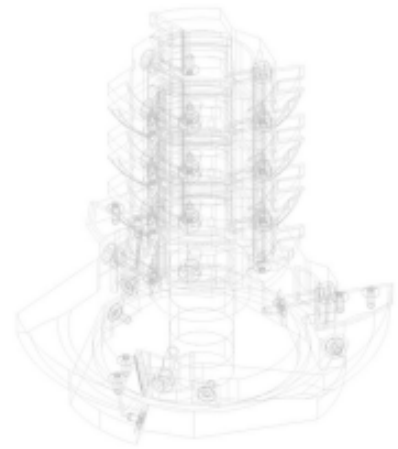

STANDARD MODEL 318 TOOLING SET

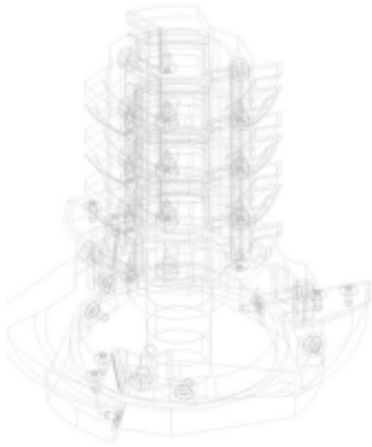

MODEL 318
STANDARD CUTTERS
The drawing shows a typical stack for this machine model

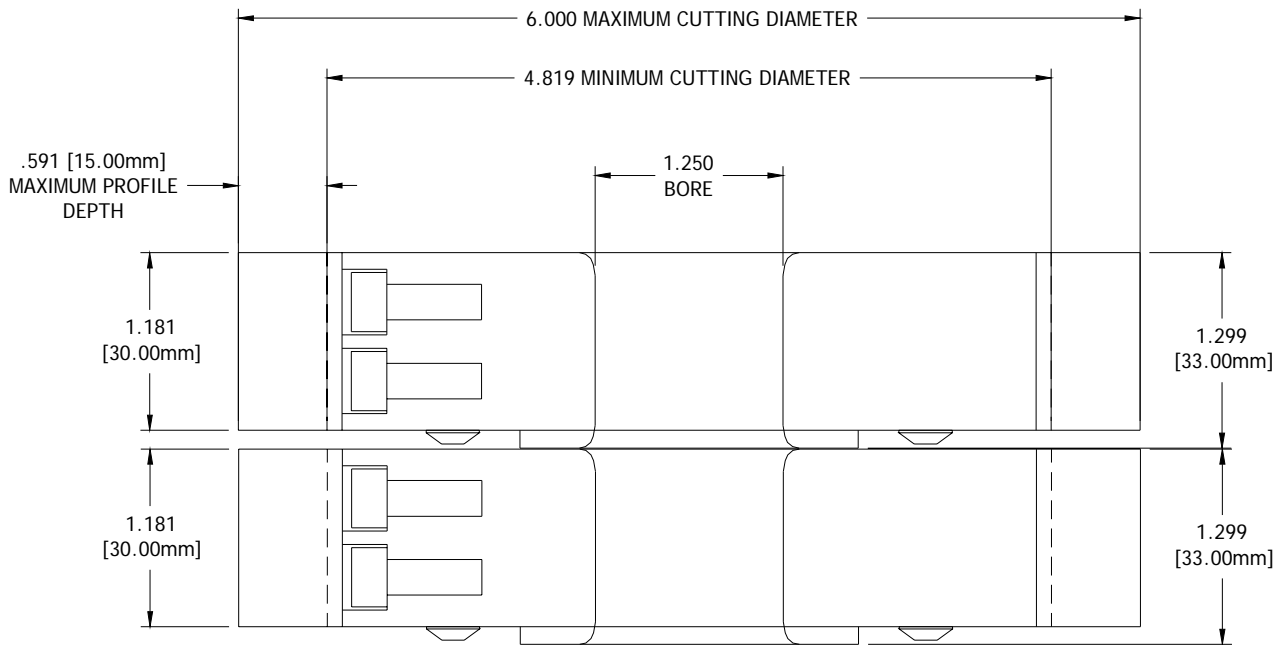

2008 Version 4.1

TOOLING CONFIGURATIONS

STANDARD MODEL 319S / 319SS TOOLING SET



MODEL 319S/319SS STANDARD CUTTERS



The drawing shows a typical stack for this machine model

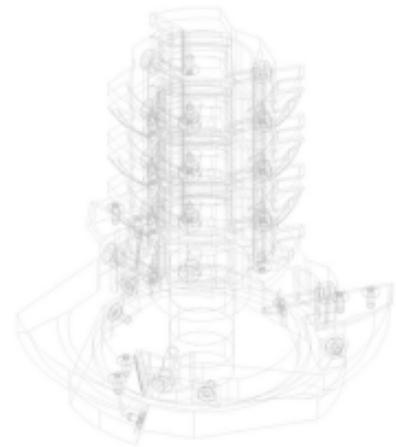

TOOLING CONFIGURATIONS

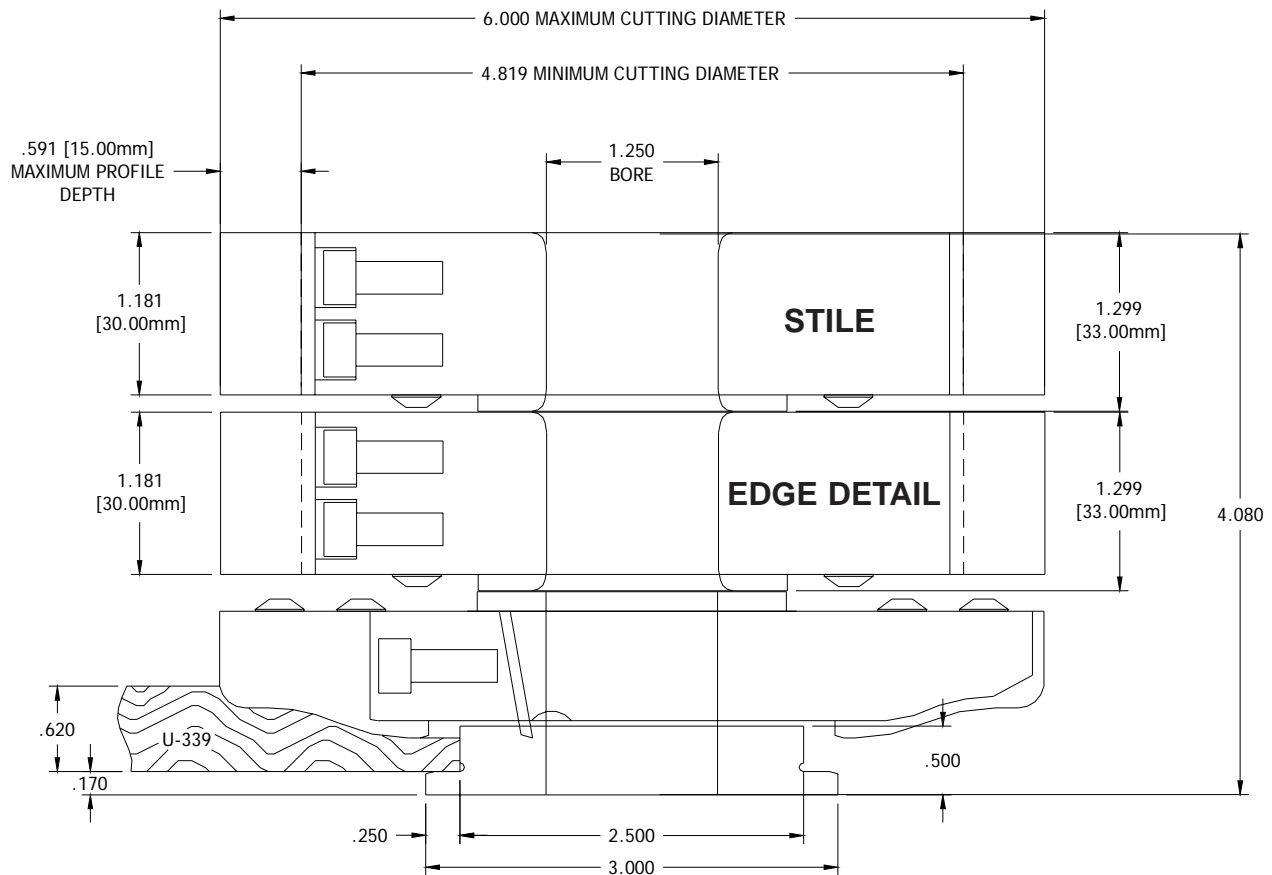

2008 Version 4.1

STANDARD MODEL 4522 TOOLING SET

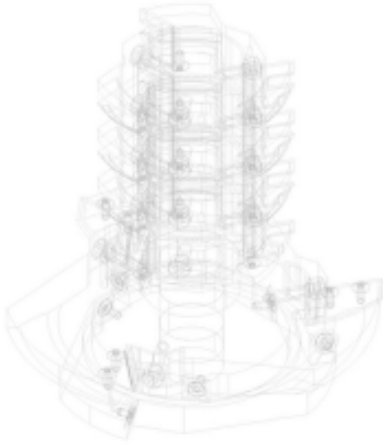

MODEL 4522
STANDARD CUTTERS
The drawing shows a typical
stack for this machine model



2008 Version 4.1

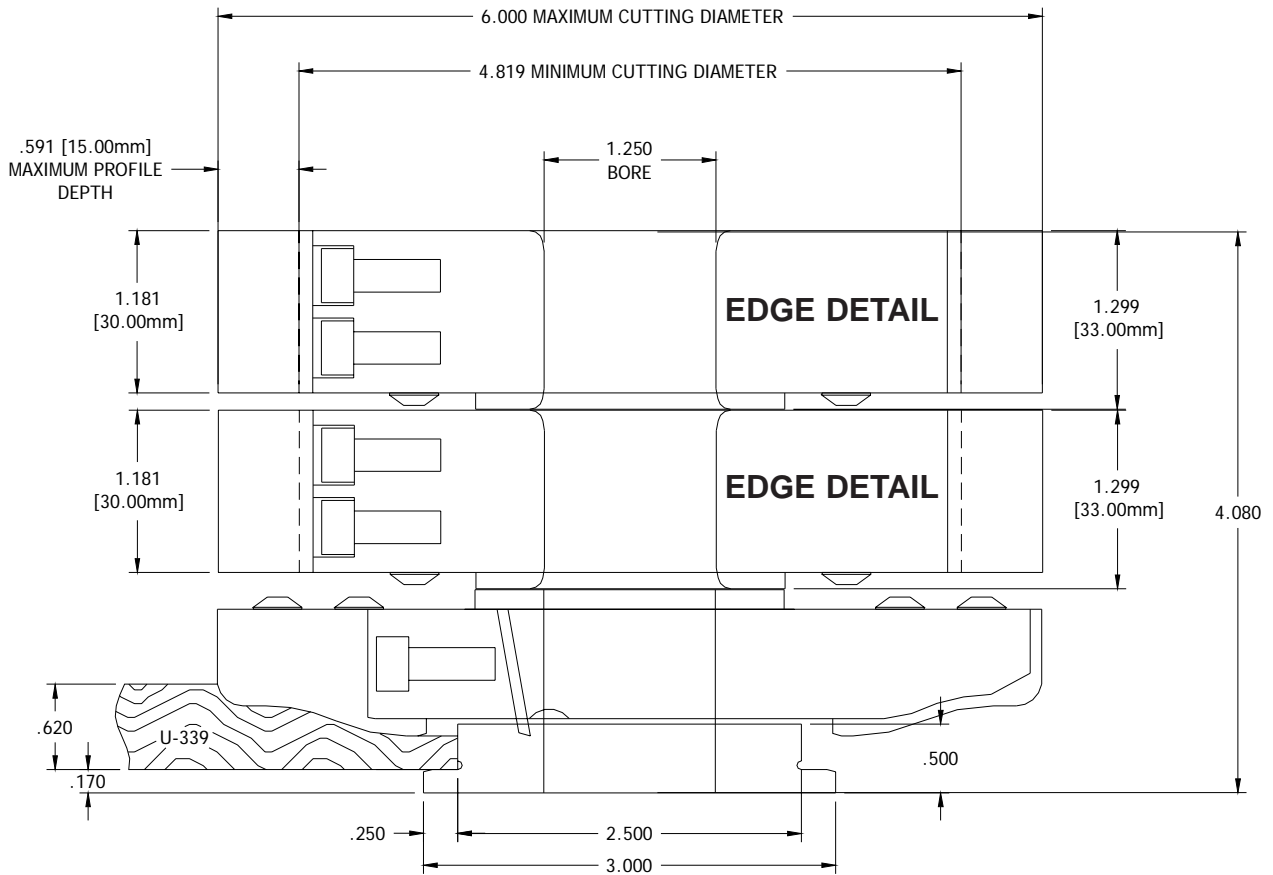

TOOLING CONFIGURATIONS

STANDARD MODEL 2752 TOOLING SET



MODEL 2752
STANDARD CUTTERS
The drawing shows a typical
stack for this machine model

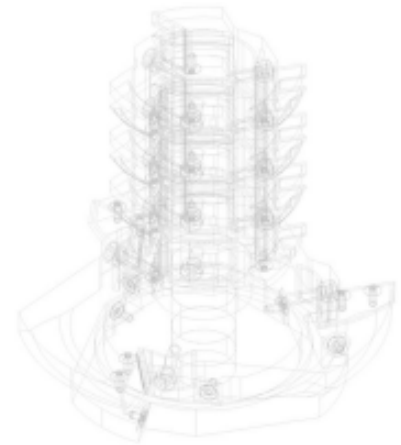

TOOLING CONFIGURATIONS

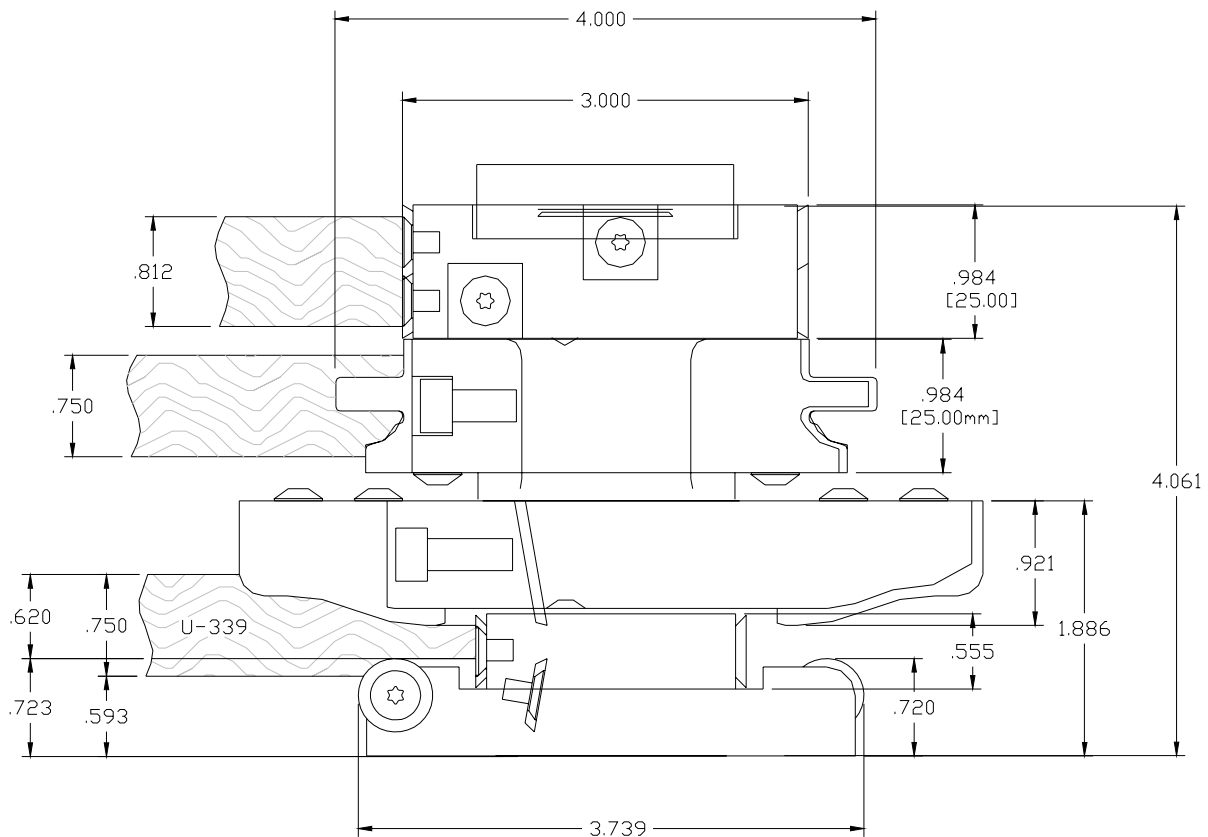

2008 Version 4.1

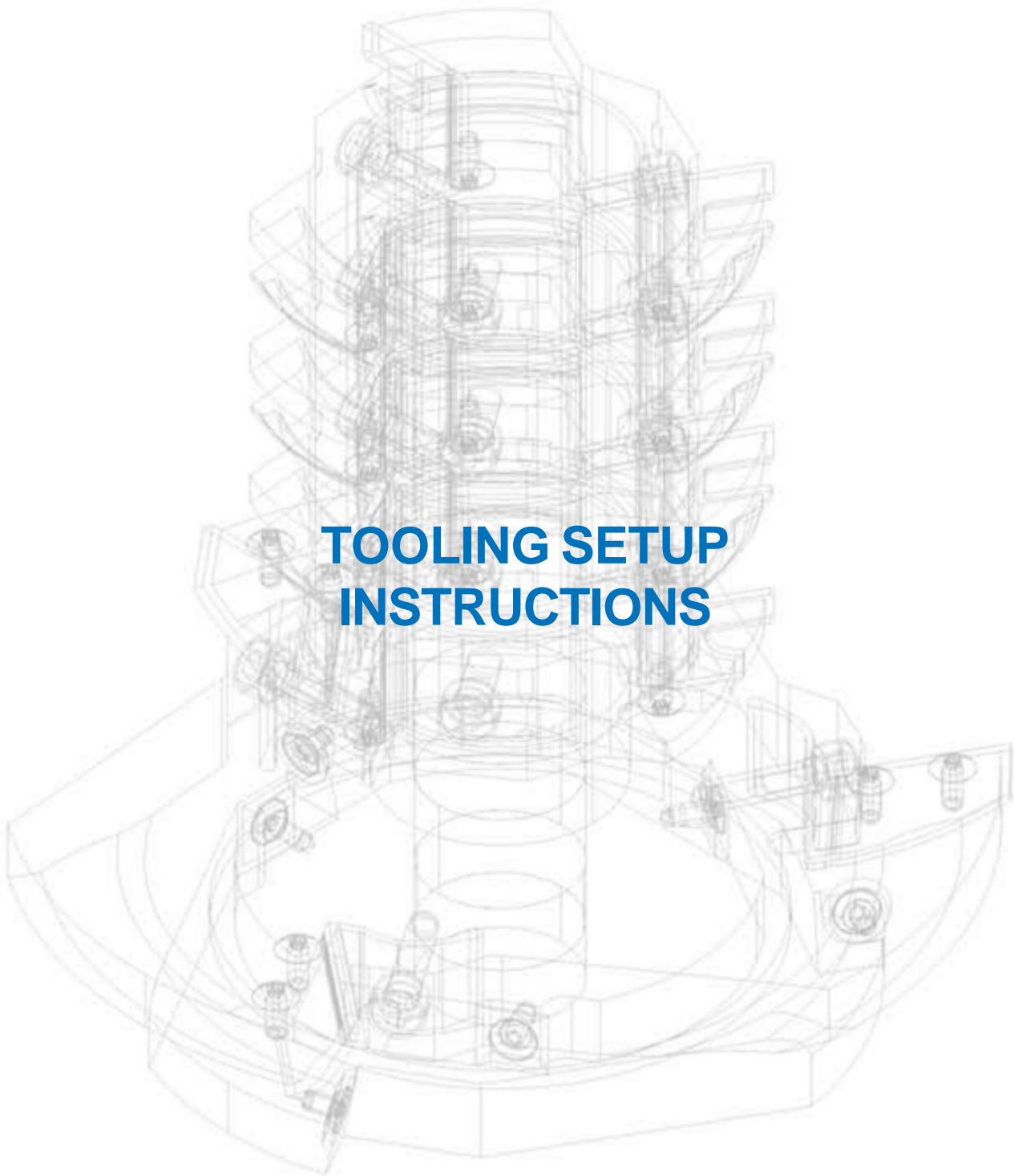

**TOOLING SETUP
INSTRUCTIONS**

FOR GREAT-LOC® SG UNIVERSAL TOOL SYSTEM

Note: Instructions are for a typical cutter. The cutter shown may not look identical to your cutter.

1. Unique Tooling Department recommends the use of **safety glasses at all times.**
2. When cutter is mounted on the machine, be sure to follow **LockOut/TagOut** procedures and use all appropriate personal protection equipment.
3. Remove cutter from machine.
4. Place Cutter in a setup stand to change inserts. Setup stand must be fastened to a solid work bench or table.

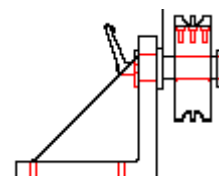

Setup stand

Setup stand & accessories can be purchased from the Unique Tooling Department. **Order#** C955-07584-0000 Stand Assy.

Insert Removal

1. Use a 5-millimeter hex key to loosen the 6-mm clampscrews. It is not necessary to remove these screws. Remove screws occasionally (after 2-4 insert replacements) to reapply Anti-Seize.
2. **Do not remove the stopscrews**, which are the screws located on the side of the cutter.
3. With clampscrews loosened, slide the insert out to the side opposite the stopscrew.

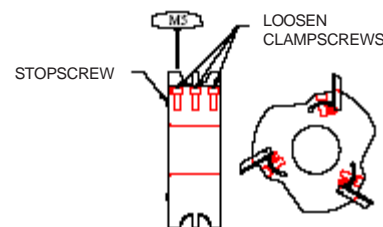

Insert Installation

1. With all inserts removed, clean cutters and insert slots using an air hose to blow out any loose material. Remove wood pitch or "caked on material" using hot water or a cleaning solvent.
2. Before reinstalling screws apply a small amount of anti-seize, which was supplied with your cutter, on the threads and under the head of each screw.
3. Slide the insert and backer plate into the slot, making sure the standing ridge of the clamp face is within the groove of the insert and the standing ridge of the body is within the groove of the backer plate. Slide the insert and backer plate in until they stop against the stopscrew.
4. Hold the insert & backer plate against the stopscrew and against the flat bottom surface of the slot. **Be careful the insert is sharp and can cut you.** The groove in the insert and the standing ridge in the clamp face are for safety only and do not in any way locate the insert.
5. Applying pressure to hold the insert in place, tighten the clampscrews only enough to hold the insert in place.
6. Using a torque wrench with a hex bit, tighten each clampscrew to the correct torque.

(See Clampscrew Tightening Instructions - Page 13)

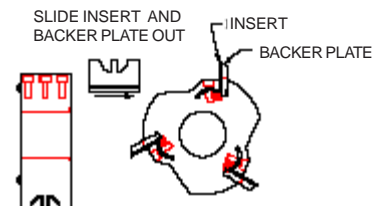

1. After lightly hand tightening the clampscrews with a T-handle allen wrench, use a torque wrench to tighten each screw to **140-145** Inch pounds for 6mm screws with 5mm hex key size. Tighten each screw a small amount at a time following the tightening sequence below. Do not tighten the screw directly to the torque value stated. Tightening each screw a small amount at a time applies equal pressure to the clamp and helps keep the insert precisely in place.

(Note: The torque value stated is Anti-Seize lubricated torque value. Never torque a screw without Anti-Seize to this amount, false torque and/or failure could occur.)

2. After all the clampscrews in one wing are fully tightened, move to the wing directly across the cutter body and tighten those clampscrews. On a 3 wing cutter after tightening all the clampscrews on one wing, move on to either one of the remaining 2 wings and tighten those clampscrews. Follow this pattern until all the clampscrews on all the wings are tight.

2008 Version 4.1

Side View of Cutter
(some cutters may contain only one screw)

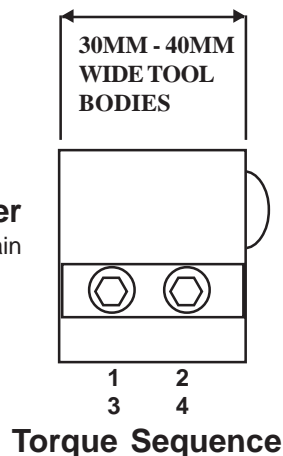

SYNERGY SPACERS



WHY USE SPACERS?

- Center panels during door assembly.
- Allows for natural expansion & contraction of center panel.
- Reduce panel rattle.
- Reduce cracking of glue joints.



Go Green Inserter

HOW ARE SPACERS USED?

- 8-10 Spacers are recommended per five piece door.
- Spacers sit snugly in groove.
NOTE: Panel should not compress more than half the diameter of the spacer
- Use the Unique "Go Green" Inserter shown - No air or electricity required.

WHAT MAKES SYNERGY SPACERS UNIQUE?

- **100% Green Product - NO** oil, no carbon black or Phthalates!
- Will not stain wood or leave spots on doors.
- New cutting edge TPC material provides compressibility & memory retention.

Synergy Spacers - The Natural Choice!



LAMELLO LK GLUE SYSTEMS

- LK 3 - 1 Gallon Glue System - PN# 530-692-002
- LK 5 - 1.5 Gallon Glue System - PN# 530-690-000
- LK 10 - 3 Gallon Glue System - PN# 530-690-001



PROFILE MATCHED GLUE NOZZELS

- Many standard sizes available.
- Custom Profiles upon request.
- Prevents glue overflow



LAMELLO BEECHWOOD MITER JOINT BISCUITS

- #20 - 1000/Box - PN# 144020
- #10 - 1000/Box - PN# 144010
- #0 - 1000/Box - PN# 144000
- Assorted - 1000/Box - PN# 144030
(Asst contains 500 #20's, 250 #10's, 250 # 0's)



**PLEASE CALL FOR MORE DETAILS
MANY MORE LAMELLO PRODUCTS AVAILABLE !**



**UNIQUE MACHINE & TOOL OFFERS
A COMPLETE
TOOLING SOLUTION**

**CALL 602-470-1911
FOR ALL
YOUR TOOLING NEEDS**

UNIQUE
MACHINE & TOOL CO.

**4232 E. Magnolia St.
Phoenix, Arizona 85034 U.S.A.**

**Website: www.uniquemachine.com
Email: tooling@uniquemachine.com**

**Phone: (602)470-1911
Fax: (602)470-1916**